

Panasonic

Operating Instructions

Multi-Function Printer

Model No. **KX-MB263HX**

KX-MB773EX

KX-MB773FX

KX-MB783EX

KX-MB783FX

This pictured model is KX-MB263.

www.beophone.co.rs

Do NOT connect the USB cable until prompted by the Multi-Function Station (CD-ROM).

1

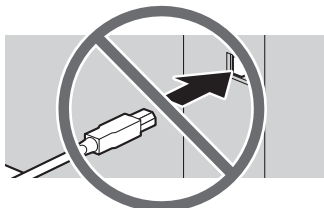

2

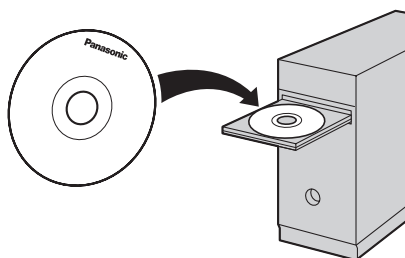

KX-MB773EX/KX-MB773FX/KX-MB783EX/KX-MB783FX only:

- This unit is compatible with Caller ID. To use this feature, you must subscribe to the appropriate service of your service provider.

KX-MB773EX/KX-MB783EX only:

- This model is designed to be used in Czech, Hungary and Slovakia according to the location setting feature. The default setting is Czech. To change the location setting, see page 56 (feature #114).

Thank you for purchasing a Panasonic Multi-Function Printer.

User record (for your future reference)

Date of purchase

Serial number (found on the rear of the unit)

Dealer's name and address

Dealer's telephone number

Attach your sales receipt here.

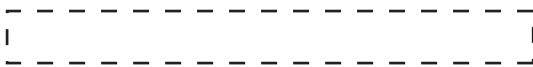

You can select Czech, Hungarian, Slovak or English for the language (KX-MB263HX/KX-MB773EX/KX-MB783EX only).

The display and reports will be in the selected language. The default setting is Czech. If you want to change the setting, see feature #110 on page 56.

This model is designed to be used in Czech, Hungary and Slovakia according to the location setting feature (KX-MB773EX/KX-MB783EX only).

The default setting is Czech. To change the location setting, see page 56 (feature #114).

Caution:

- Do not rub or use an eraser on the printed side of recording paper, as the print may smear.
- In the event of problems, you should contact your equipment supplier in the first instance (KX-MB773/KX-MB783 only).
- This equipment is designed for use on the Hungary, Czech and Slovakia analogue telephone network (KX-MB773EX/KX-MB783EX only).

Note:

- The suffix in the model number will be omitted in these instructions.
- Most figures shown in these operating instructions are based on a KX-MB263.

Declaration of Conformity (KX-MB773/KX-MB783 only):

- Panasonic Communications Co., Ltd. declares that this equipment is in compliance with the essential requirements and other relevant provisions of Radio

& Telecommunications Terminal Equipment (R&TTE) Directive 1999/5/EC.

Declarations of Conformity for the relevant Panasonic products described in this manual are available for download by visiting:
<http://www.doc.panasonic.de>

Contact:

Panasonic Services Europe
a Division of Panasonic Marketing Europe GmbH
Panasonic Testing Centre
Winsbergring 15, 22525 Hamburg, Germany

Information of Compliance with EU relevant Regulatory Directives (KX-MB263 only):

- Contact:
Panasonic Services Europe
a Division of Panasonic Marketing Europe GmbH
Panasonic Testing Centre
Winsbergring 15, 22525 Hamburg, Germany

Notice for product disposal, transfer, or return (KX-MB773/KX-MB783 only):

- This product can store your private/confidential information. To protect your privacy/confidentiality, we recommend that you erase the information such as phonebook (or caller information) from the memory before you dispose, transfer or return the product.

Trademarks:

- Microsoft, Windows, Windows Vista, Internet Explorer and PowerPoint are either registered trademarks or trademarks of Microsoft Corporation in the United States and/or other countries.
- Pentium is a registered trademark or trademark of Intel Corporation in the United States and/or other countries.
- Screen shots reprinted with permission from Microsoft Corporation.
- Adobe and Reader are either registered trademarks or trademarks of Adobe Systems Incorporated in the United States and/or other countries.
- Avery is a registered trademark of Avery Dennison Corporation.
- XEROX is a registered trademark of Xerox Corporation.
- All other trademarks identified herein are the property of their respective owners.

Copyright:



- This material is copyrighted by Panasonic Communications Co., Ltd., and may be reproduced for internal use only. All other reproduction, in whole or in part, is prohibited without the written consent of Panasonic Communications Co., Ltd.

© 2007 Panasonic Communications Co., Ltd. All Rights Reserved.



For your safety

To prevent severe injury and loss of life/property, read this section carefully before using the unit to ensure proper and safe operation of your unit.

- **The following symbols are used to classify and describe the level of hazard and injury caused when the denotation is disregarded and improper use is performed.**

	WARNING
Denotes a potential hazard that could result in serious injury or death.	
	CAUTION
Denotes hazards that could result in minor injury or damage to the unit.	

- **The following symbols are used to classify and describe the type of instructions to be observed.**

	This type of symbol is used to alert users to a specific operating procedure that must be performed carefully.
	This type of symbol is used to alert users to a specific operating procedure that must not be performed.
	This type of symbol is used to alert users to a specific operating procedure that must be emphasized in order to operate the unit safely.



Power and ground connection



Use only the power source marked on the unit. If you are not sure of the type of power supplied to your home, consult your dealer or local power company.



For safety purposes this unit is equipped with a grounded plug. If you do not have this type of outlet, please have one installed. Do not defeat this safety feature by tampering with the plug.



Do not place objects on the mains lead. Install the unit where no one can step or trip on the cord.



Do not overload power outlets and extension cords. This can result in the risk of fire or electric shock.



Completely insert the AC adaptor/power plug into the power outlet. Failure to do so may cause electric shock and/or excessive heat resulting in a fire.



Regularly remove any dust, etc. from the AC adaptor/power plug by pulling it from the power outlet, then wiping with a dry cloth. Accumulated dust may cause an insulation defect from moisture, etc. resulting in a fire.



Unplug this unit from power outlets if it emits smoke, an abnormal smell or makes unusual noise. These conditions can cause fire or electric shock. Confirm that smoke has stopped and contact an authorised service centre.



Never touch the plug with wet hands. Danger of electric shock exists.

Installation



Place the unit securely on a stable levelled surface. Serious damage and/or injury may result if the unit falls.



To prevent the risk of fire or electrical shock, do not expose this product to rain or any type of moisture.

Important Information



Make sure that the unit is installed in a well ventilated room so as not to increase density of ozone in the air. Since ozone is heavier than air, it is recommended that air at floor level be ventilated.

Operating safeguards



Unplug this unit from power outlets before cleaning. Do not use liquid or aerosol cleaners.



Do not cover slots and openings on the unit. They are provided for ventilation and protection against overheating. Never place the unit near radiators, or in a place where proper ventilation is not provided.



Never push any objects through slots in this unit. This may result in the risk of fire or electric shock. Never spill any liquid on the unit.



To reduce the risk of electric shock, do not disassemble this unit. Take the unit to an authorised service centre when service is required. Opening or removing covers may expose you to dangerous voltage or other risks. Incorrect reassembly can cause electric shock when the unit is subsequently used.



Follow all warnings and instructions marked on this unit.



Do not spill liquids (detergents, cleansers, etc.) onto the telephone line cord plug, or allow it to become wet at all. This may cause a fire. If the telephone line cord plug becomes wet, immediately pull it from the telephone wall jack, and do not use (KX-MB773/KX-MB783 only).



Unplug this unit from power outlets and refer servicing to an authorised service centre when the following conditions occur:

- If the power cord is damaged or frayed.
- If liquid has been spilled into the unit.
- If the unit has been exposed to rain or water.
- If the unit does not work normally by following the operating instructions. Adjust only controls covered by the operating instructions. Improper adjustment may require extensive work by an authorised service centre.
- If the unit has been dropped or physically damaged.
- If the unit exhibits a distinct change in performance.



CAUTION

Installation and relocation



After moving the unit from cold areas to warmer areas, let the unit adjust to the warmer temperature and do not connect the unit for about 30 minutes. If the unit is connected too soon after a sudden climate change, condensation may form inside the unit causing malfunction.



Never install telephone wiring during a lightning storm (KX-MB773/KX-MB783 only).



Never install telephone jacks in wet locations unless the jack is specifically designed for wet locations (KX-MB773/KX-MB783 only).



Never touch uninsulated telephone wires or terminals unless the telephone line has been disconnected at the network interface (KX-MB773/KX-MB783 only).



Use caution when installing or modifying telephone lines (KX-MB773/KX-MB783 only).



When moving the unit, make sure you are using the side grips (①).

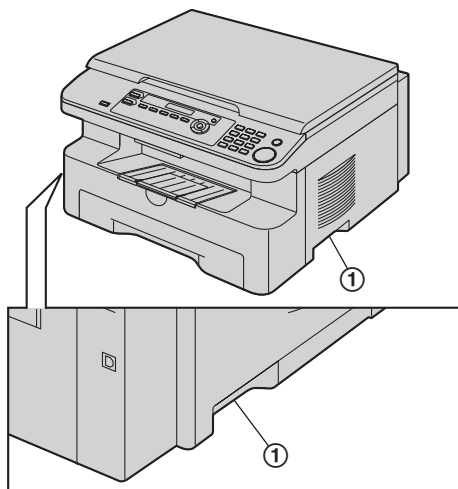

Laser radiation

CLASS 1 LASER PRODUCT



The printer of this unit utilises a laser. Use of controls or adjustments or performance of procedures other than those specified herein may result in hazardous radiation exposure.

Laser diode properties

Laser output : 5 mW max
Wavelength : 760 nm – 810 nm
Emission duration : Continuous

Fuser unit



The fuser unit (②) gets hot. Do not touch it.

Note:

- During or immediately after printing, the area near the recording paper exit (③) also gets warm. This is normal.

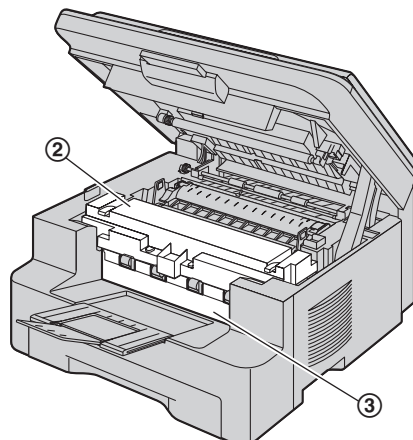

Toner cartridge

Be careful of the following when you handle the toner cartridge:



If you ingest any toner, drink several glasses of water to dilute your stomach contents, and seek immediate medical treatment.



If any toner comes into contact with your eyes, flush them thoroughly with water, and seek medical treatment.



If any toner comes into contact with your skin, wash the area thoroughly with soap and water. If there is skin irritation, seek immediate medical treatment.



If you inhale any toner, move to an area with fresh air and consult local medical personnel.

Important safety instructions

When using this unit, basic safety precautions should always be followed to reduce the risk of fire, electric shock, or personal injury.

1. Do not use this unit near water, for example near a bathtub, wash bowl, kitchen sink, etc.
2. During thunderstorms, avoid using telephones except cordless types. There may be a remote risk of an electric shock from lightning (KX-MB773/KX-MB783 only).
3. Do not use this unit to report a gas leak, when in the vicinity of the leak (KX-MB773/KX-MB783 only).

SAVE THESE INSTRUCTIONS

Information on Disposal for Users of Waste Electrical & Electronic Equipment (private households)

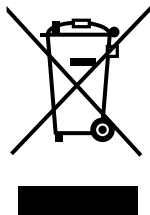

This symbol on the products and/or accompanying documents means that used electrical and electronic products should not be mixed with general household waste.

For proper treatment, recovery and recycling, please take these products to designated collection points, where they will be accepted on a free of charge basis. Alternatively, in some countries you may be able to return your products to your local retailer upon the purchase of an equivalent new product.

Disposing of this product correctly will help to save valuable resources and prevent any potential negative effects on human health and the environment which could otherwise arise from inappropriate waste handling. Please contact your local authority for further details of your nearest designated collection point. Penalties may be applicable for incorrect disposal of this waste, in accordance with national legislation.

For business users in the European Union

If you wish to discard electrical and electronic equipment, please contact your dealer or supplier for further information.

Information on Disposal in other Countries outside the European Union

This symbol is only valid in the European Union. If you wish to discard this product, please contact your local authorities or dealer and ask for the correct method of disposal.

For best performance

Toner cartridge and drum unit

- When replacing the toner cartridge or drum unit, do not allow dust, water, or liquids to come in contact with the drum. This may affect print quality.
- For optimal performance, genuine Panasonic toner cartridges and drum units are recommended. We cannot be responsible for problems that may be caused by a non-Panasonic toner cartridge or drum unit:
 - Damage to the unit
 - Poor print quality
 - Improper operation

Toner cartridge

- Do not leave the toner cartridge out of the protection bag for a long time. It will decrease the toner life.

Drum unit

- Read the instructions on page 13 before you begin installation of the drum unit. After you have read them, open the drum unit protection bag. The drum unit contains a photosensitive drum. Exposing it to light may damage the drum. Once you have opened the protection bag:
 - Do not expose the drum unit to light for more than 5 minutes.
 - Do not touch or scratch the black drum surface.
 - Do not place the drum unit near dust or dirt, or in a high humidity area.
 - Do not expose the drum unit to direct sunlight.
- To extend the life of the drum unit, the unit should never be turned OFF immediately after printing. Leave the power turned ON for a minimum of 30 minutes after printing.

Location

- To avoid malfunction, do not position the unit near appliances such as TVs or speakers which generate an intense magnetic field.

Static electricity

- To prevent static electricity damage to the interface connectors or other electrical components inside the unit, touch a grounded metal surface before touching the components.

Environment

- Keep the unit away from electrical noise generating devices, such as fluorescent lamps and motors.
- The unit should be kept free from dust, high temperature and vibration.
- The unit should not be exposed to direct sunlight.
- Do not place heavy objects on top of the unit. When you leave the unit unused for a long period of time, unplug this unit from the power outlet.
- The unit should be kept away from heat sources such as heaters, kitchen stoves, etc. Damp basements should also be avoided.

- In the printing process, heat is used to fuse toner onto the page. As a result, it is normal for the machine to produce an odour during and shortly after printing. Be sure to use this unit in an area with proper ventilation.
- Do not place any objects within 10 cm of the right, left and back sides of the unit.
- Do not cover slots or openings on the unit. Inspect the air circulation vents regularly and remove any dust build-up with a vacuum cleaner (①).

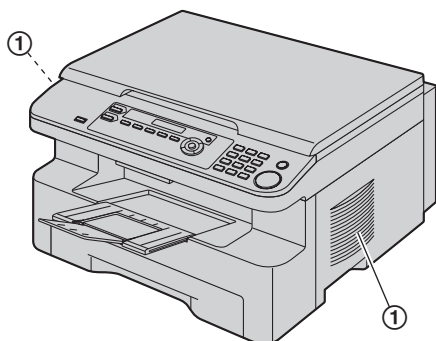

Routine care

- Wipe the outer surface of the unit with a soft cloth. Do not use benzine, thinner, or any abrasive powder.

1. Introduction and Installation

Accessories

- 1.1 Included accessories..... 10
- 1.2 Accessory information..... 11

Finding the Controls

- 1.3 Button descriptions..... 11
- 1.4 Overview 12

Installation

- 1.5 Toner cartridge and drum unit 13
- 1.6 Output tray..... 16
- 1.7 Recording paper..... 18
- 1.8 Handset unit (KX-MB773/KX-MB783 only) . 19

2. Preparation

Connections and Setup

- 2.1 Connections 21
- 2.2 Dialling mode (KX-MB773/KX-MB783 only) 22
- 2.3 Selecting the operation mode (Scan/Copy) (Fax: KX-MB773/KX-MB783 only)..... 22

Document Requirements

- 2.4 Setting the original..... 23

Help

- 2.5 Help function (KX-MB773/KX-MB783 only). 24

Volume

- 2.6 Adjusting volume (KX-MB773/KX-MB783 only) 25

Initial Programming

- 2.7 Date and time (KX-MB773/KX-MB783 only) 25
- 2.8 Your logo (KX-MB773/KX-MB783 only)..... 26
- 2.9 Your fax number (KX-MB773/KX-MB783 only) 26
- 2.10 Configuring the unit to access the LAN (KX-MB783 only) 27
- 2.11 Installing Multi-Function Station 28
- 2.12 Starting Multi-Function Station 30

3. Printer

Printer

- 3.1 Printing from Windows applications 31

4. Scanner

Scanner

- 4.1 Scanning from the unit (Push Scan)..... 33
- 4.2 Scanning from a computer (Pull Scan)..... 35

5. Copier

Copy

- 5.1 Making a copy 36
- 5.2 More copying features 37

6. Telephone (KX-MB773/KX-MB783 only)

Automatic Dialling

- 6.1 Storing items for the one-touch dial feature and navigator directory41
- 6.2 Making a phone call using one-touch dial feature or navigator directory41

7. Fax (KX-MB773/KX-MB783 only)

Sending Faxes

- 7.1 Sending a fax manually43
- 7.2 Sending a fax using one-touch dial feature and navigator directory45
- 7.3 Broadcast transmission.....45
- 7.4 Sending a computer document as a fax message from your computer47

Receiving Faxes

- 7.5 Selecting the way to use your fax machine ..47
- 7.6 Receiving a fax automatically – Auto answer ON.....48
- 7.7 Receiving a fax manually – Auto answer OFF49
- 7.8 Using the unit with an answering machine...50
- 7.9 Receive polling (retrieving a fax placed on another fax machine)51
- 7.10 Junk fax prohibitor (preventing fax reception from undesired callers).....51
- 7.11 Receiving a fax into your computer.....52

8. Caller ID (KX-MB773/KX-MB783 only)

Caller ID

- 8.1 Caller ID service.....53
- 8.2 Viewing and calling back using caller information53
- 8.3 Editing a caller's telephone number before calling back/storing.....53
- 8.4 Erasing caller information.....54
- 8.5 Storing caller information54

9. Programmable Features

Features Summary

- 9.1 Programming.....55
- 9.2 Basic features56
- 9.3 Fax features (KX-MB773/KX-MB783 only)...59
- 9.4 Copy features63
- 9.5 PC print features63
- 9.6 Scan features64
- 9.7 LAN features (KX-MB783 only)65
- 9.8 Network features (KX-MB783, LAN connection only)67

10. Useful Information

Useful Information

- 10.1 Character entry (KX-MB773/KX-MB783 only) 68
- 10.2 Status of the unit 69
- 10.3 Cancelling the operations 69

11. Help

Error Messages

- 11.1 Error messages – Reports (KX-MB773/KX-MB783 only) 71
- 11.2 Error messages – Display 72

Troubleshooting

- 11.3 When a function does not work 74

12. Paper Jams

Jams

- 12.1 Recording paper jam 82
- 12.2 Document jams (Auto document feeder) (KX-MB773/KX-MB783 only) 87

13. Cleaning

Cleaning

- 13.1 Cleaning the white plates and glass 88
- 13.2 Cleaning the document feeder rollers (KX-MB773/KX-MB783 only) 91

14. General Information

Printed Reports

- 14.1 Reference lists and reports 92

Specifications

- 14.2 Specifications 92

Copyrights

- 14.3 Information of copyrights and licences (KX-MB783 only) 95

15. Index

- 15.1 Index 102

1. Introduction and Installation

1.1 Included accessories

① Power cord

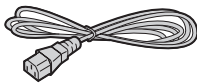

② CD-ROM



③ Drum unit

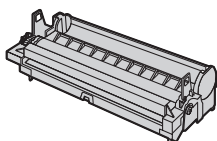

④ Starter toner cartridge*1

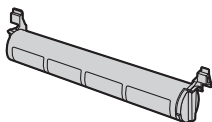

⑤ Operating instructions
(English only)



⑥ **KX-MB263HX/
KX-MB773EX/
KX-MB783EX only**
Quick reference guide



⑦ Quick installation guide

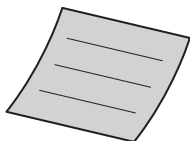

⑧ **KX-MB773/KX-MB783
only**
Telephone line cord



⑨ **KX-MB773/KX-MB783
only**
Handset



⑩ **KX-MB773/KX-MB783
only**
Handset cord

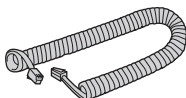

⑪ **KX-MB773/KX-MB783
only**
Handset cradle

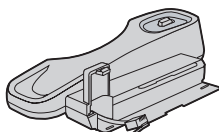

*1 Prints about 500 A4-sized pages with a 5 % image area (page 94).

Note:

- Save the original carton and packing materials for future shipping and transportation of the unit.

1.2 Accessory information

To ensure that the unit operates properly, we recommend the use of a Panasonic toner cartridge and drum unit. See page 94 for specifications.

1.2.1 Available accessories

- Replacement toner cartridge*¹
 - Model No. (Part No.): KX-FAT92E/KX-FAT92X
- Replacement drum unit
 - Model No. (Part No.): KX-FAD93E/KX-FAD93X

*1 Approx. 2,000 sheets of A4 size paper can be printed with KX-FAT92E/KX-FAT92X.

1.3 Button descriptions

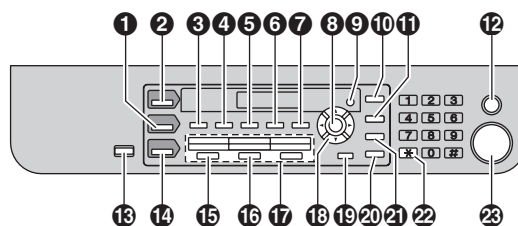

* The small hole on the left side of the LCD display is for beeps (KX-MB263 only).

* The pictured model is KX-MB773/KX-MB783.

- 1 [COPY]**
 - To switch to the copy mode (page 22, 36).
- 2 [SCAN]**
 - To switch to the scan mode (page 22, 33).
- 3 [COLLATE]**
 - To make a collated copy (page 40).
- [DIRECTORY] (KX-MB773/KX-MB783 only)**
 - To initiate the navigator directory (page 41, 45).
- 4 [CONTRAST]**
 - To select a contrast (page 36, 43).
- 5 [RESOLUTION]**
 - To select a resolution (page 36, 43).
- 6 [ZOOM]**
 - To enlarge or reduce a document when copying (page 37).
- [QUICK SCAN] (KX-MB773/KX-MB783 only)**
 - To store a scanned document into memory, and then send it (page 44).
- 7 [PAGE LAYOUT]**
 - To make quick ID, poster or N in 1 copy (page 38).
- 8 [SET]**
 - To store a setting during programming.
- 9 [MENU]**
 - To start or exit programming.
- 10 [CALLER ID] (KX-MB773/KX-MB783 only)**
 - To use Caller ID features (page 53).
 - To change the display of the caller information (page 53).
- 11 [REDIAL][PAUSE] (KX-MB773/KX-MB783 only)**
 - To redial the last number dialed. If the line is busy when you make a phone call using the [MONITOR] button, or when you send a fax, the unit will automatically redial the number 2 or more times.
 - To insert a pause during dialling.
- 12 [STOP]**
 - To stop an operation or programming session.
 - To erase a character/number.

1. Introduction and Installation

- 13 [FAX AUTO ANSWER] (KX-MB773/KX-MB783 only)**
- To turn the auto answer setting ON/OFF (page 48).
- [POWER SAVE] (KX-MB263 only)**
- To set the unit to the power save mode manually.
- 14 [FAX] (KX-MB773/KX-MB783 only)**
- To switch to the fax mode (page 22, 43).
- 15 [BROADCAST] (KX-MB773/KX-MB783 only)**
- To send a document to multiple parties (page 45).
- 16 [MANUAL BROAD] (KX-MB773/KX-MB783 only)**
- To send a document to multiple parties manually (page 45).
- 17 Station keys (KX-MB773/KX-MB783 only)**
- To use the one-touch dial feature (page 41, 45).
- 18 Navigator key**
- To select desired settings during scanning or copying (page 33, 36).
 - To adjust volume (KX-MB773/KX-MB783 only) (page 25).
 - To search for a stored item (KX-MB773/KX-MB783 only) (page 45).
- 19 [LOWER] (KX-MB773/KX-MB783 only)**
- To select stations 4–6 for the one-touch dial feature (page 41, 45).
- 20 [MONITOR] (KX-MB773/KX-MB783 only)**
- To initiate dialling.
When you press **[MONITOR]** while receiving a call, you will be able to hear the other party, but the other party will not be able to hear you.
- 21 [RECALL] (KX-MB773/KX-MB783 only)**
- To access special telephone services or for transferring extension calls.
- 22 [TONE] (KX-MB773/KX-MB783 only)**
- To change from pulse to tone temporarily during dialling when your line has rotary/pulse service.
- 23 [START]**
- To copy a document (page 36).
 - To scan a document (page 33).
 - To send or receive a fax (KX-MB773/KX-MB783 only) (page 43, 49).

1.4 Overview

1.4.1 Front view

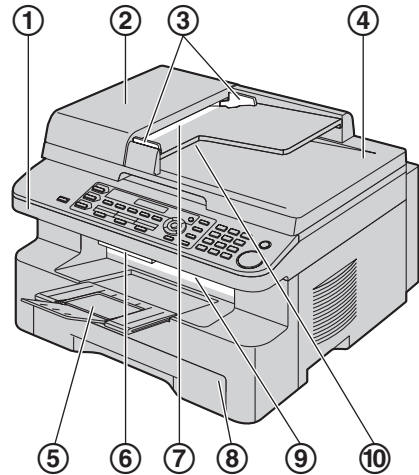

* The pictured model is KX-MB773/KX-MB783.

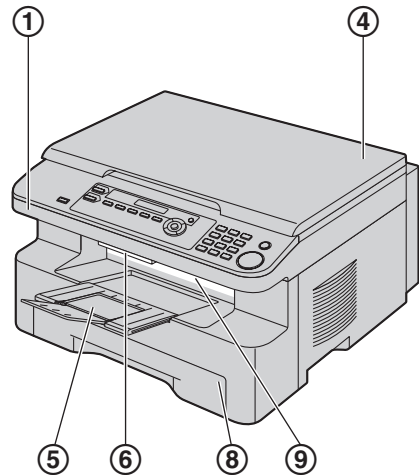

* The pictured model is KX-MB263.

- ① Top cover
- ② ADF (Auto Document Feeder) cover
- ③ Document guides
- ④ Document cover
- ⑤ Output tray
- ⑥ Top cover release lever
- ⑦ Document entrance
- ⑧ Paper input tray
- ⑨ Recording paper exit
- ⑩ Document exit

1.4.2 Rear view

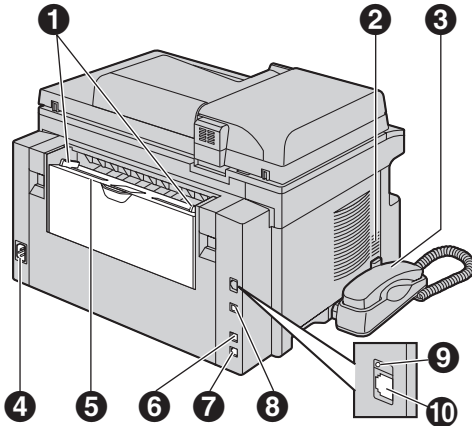

* The pictured model is KX-MB783.

- ❶ Recording paper guides
- ❷ Speaker (KX-MB773/KX-MB783 only)
- ❸ Handset (KX-MB773/KX-MB783 only)
- ❹ Power inlet
- ❺ Manual input tray (Rear cover)
- ❻ External telephone jack (KX-MB773/KX-MB783 only)
- ❼ Telephone line jack (KX-MB773/KX-MB783 only)
- ❽ USB interface connector
- ❾ LED (KX-MB783 only)
- ❿ LAN interface connector (KX-MB783 only)

Removing the shipping tape

Remove the shipping tape (❶).

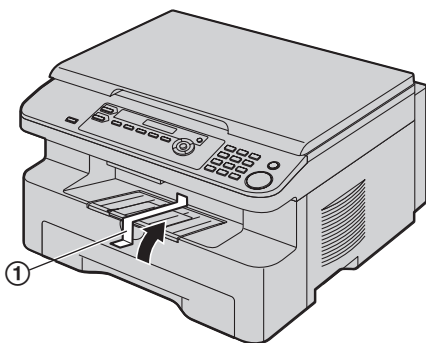

Note:

- Shipping tape positions are subject to change without notice.

1.5 Toner cartridge and drum unit

The included toner cartridge is a starter toner cartridge.

Caution:

- Read the following instructions before you begin installation. After you have read them, open the drum unit protection bag. The drum unit contains a photosensitive drum. Exposing it to light may damage the drum. Once you have opened the protection bag:
 - Do not expose the drum unit to light for more than 5 minutes.
 - Do not touch or scratch the black drum surface.
 - Do not place the drum unit near dust or dirt, or in a high humidity area.
 - Do not expose the drum unit to direct sunlight.
- We cannot be responsible for any damage to the unit or degradation of print quality which may occur from the use of a non-Panasonic toner cartridge and drum unit.
- Do not leave the toner cartridge out of the protection bag for a long time. It will decrease the toner life.
- Do not add toner to the toner cartridge.

- 1 Before opening the protection bag of the new toner cartridge, shake it vertically more than 5 times.



- 2 Remove the toner cartridge and drum unit from the protection bags. Peel off the seal (❶) from the toner cartridge.
 - Do not touch or scratch the black drum surface (❷).

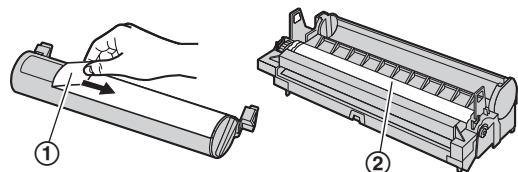

1. Introduction and Installation

- 3 Place the toner cartridge (3) into the drum unit (4) vertically.

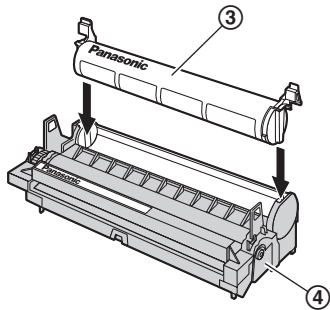

- 4 Turn the green levers (5) on each side of the toner cartridge while pressing down firmly.

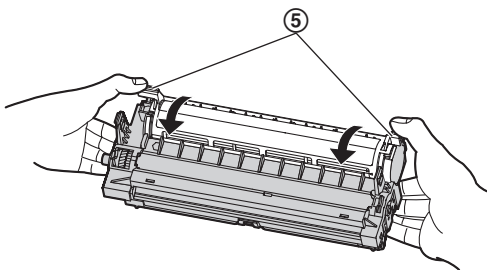

- 5 Make sure that the triangles (6) match, to install the toner cartridge correctly.

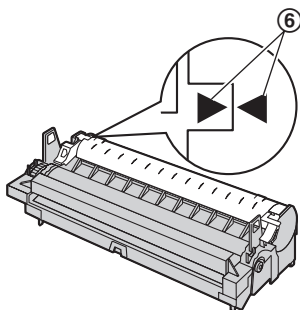

- 6 Lift the top cover release lever (7) and open the top cover (8).

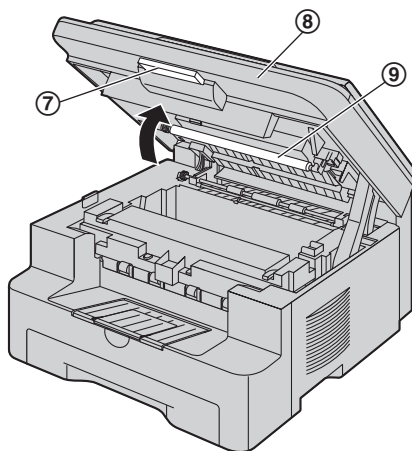

Note:

- Do not touch the transfer roller (9).
- If the lower glass (10) is dirty, clean it with a soft and dry cloth.

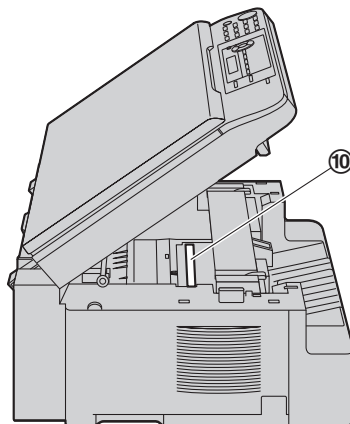

- 7 Install the drum and toner unit (11) by holding the tabs.

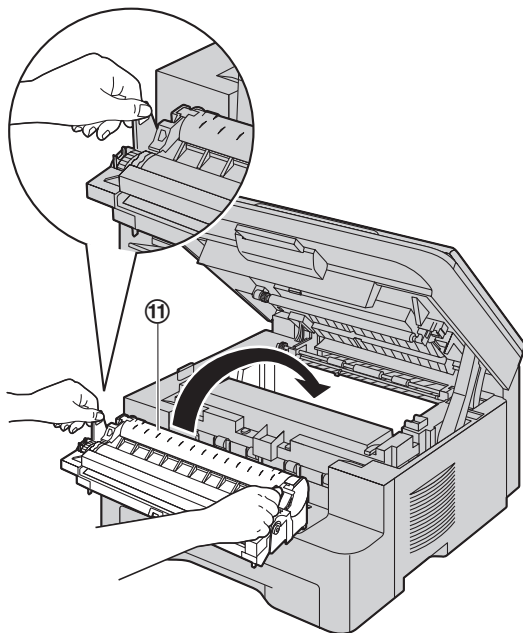

- Make sure that the triangles (12) match, to install the drum and toner unit correctly.

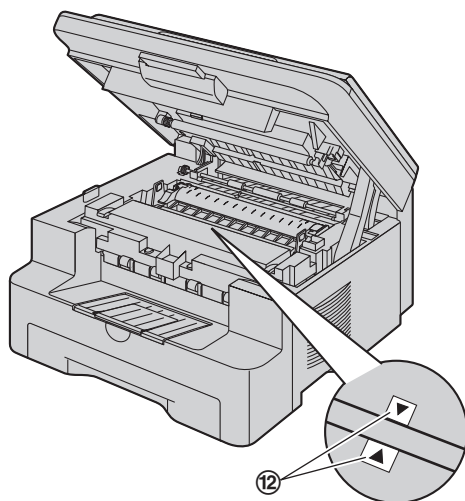

- 8 Close the top cover until locked.

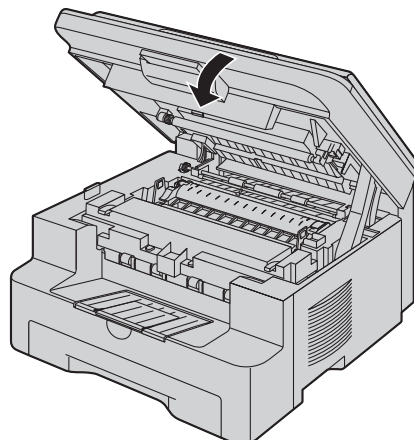

Caution:

- To prevent injuries, be careful not to put your hands under the top cover.

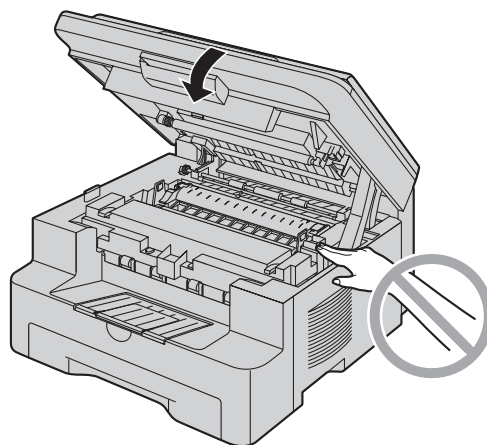

To replace the toner cartridge and the drum unit

When the display shows the following, replace the toner cartridge.

TONER LOW

TONER EMPTY

- To check the drum life and quality, please print the printer test list (page 92) and refer to page 94 for information on the drum life. If printing quality is still poor or “REPLACE DRUM” appears on the display, replace the toner cartridge and drum unit.
- To ensure that the unit operates properly, we recommend the use of **Panasonic toner cartridge (Model No. KX-FAT92E/KX-FAT92X) and drum unit (Model No. KX-FAD93E/KX-FAD93X)**. See page 11 for accessory information.

1. Introduction and Installation

- To maintain print quality and machine life, we recommend you to clean slots and openings (page 7) and the inside of the unit (page 88, 91) when replacing the toner cartridge and/or drum unit.

Waste disposal method

Waste material should be disposed of under conditions which meet all national and local environmental regulations.

Toner save feature

If you want to reduce toner consumption, set the toner save setting to ON (feature #482 on page 58). The toner cartridge will last approximately 40 % longer. This feature may lower the print quality.

1.6 Output tray

Pull the output tray extender (①) forward gently until it clicks into place, then press the centre part of the extender (②) to open.

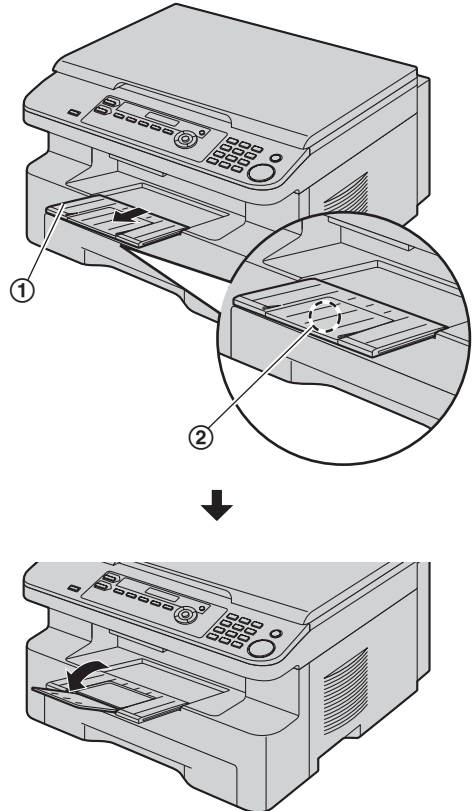

Note:

- Do not place the unit in an area where the output tray may be easily bumped into.
- The output tray can hold up to approximately 150 sheets of printed paper. Remove the printed paper before the output tray becomes full.

If the top part of the extender is detached

1. With the top part of the extender in the open position, insert the tab (①) into the left hole (②) of the extender.

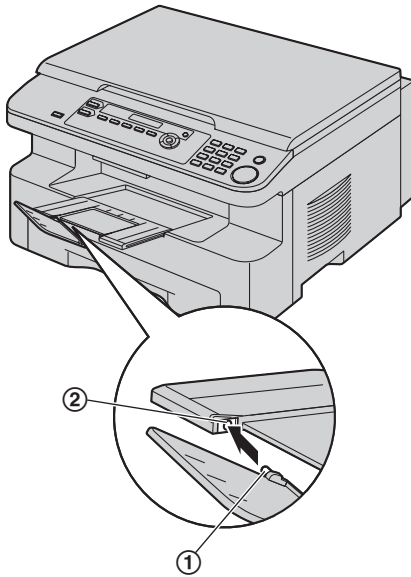

2. Slide the other tab (③) into the right hole (④) of the extender from below until it clicks into place.

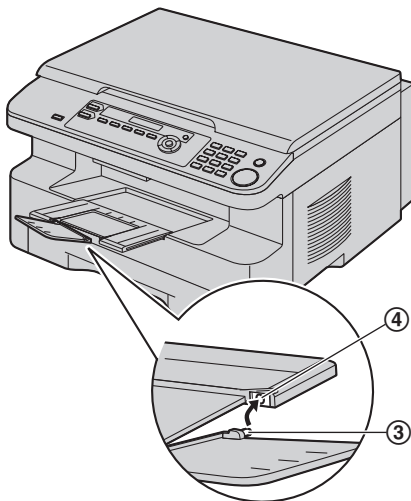

If the extender is detached

1. Line up the extender (①) with the left side of the output tray. Make sure that the triangles (②) match, to attach the extender correctly.

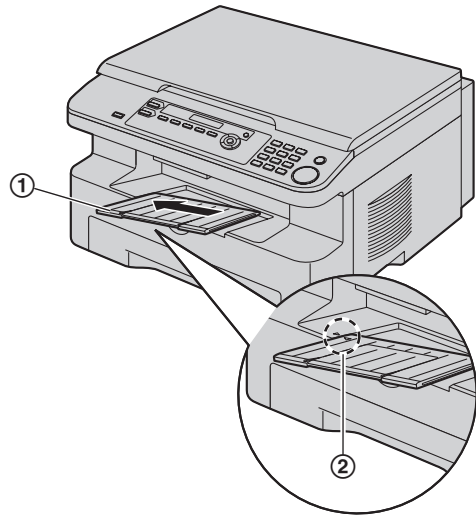

2. Snap the extender (③) into the unit by pushing down the right side of the extender.

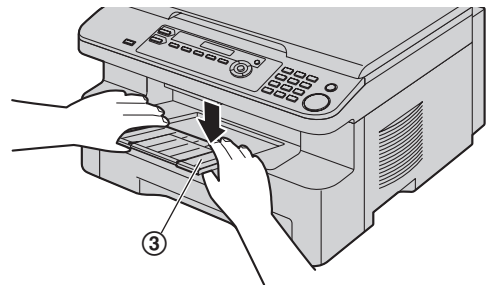

1.7 Recording paper

The paper input tray unit can hold:

- Up to 250 sheets of 60 g/m² to 75 g/m² paper.
 - Up to 230 sheets of 80 g/m² paper.
 - Up to 200 sheets of 90 g/m² paper.
- Please refer to page 93 for information on recording paper.
 - **The unit is set for printing A4 size paper by default. If you want to use letter or legal size paper, change the setting (feature #380 on page 57).**
- 1** Pull the paper input tray (①) until it clicks into place, then pull it completely out, lifting the front part of the tray.

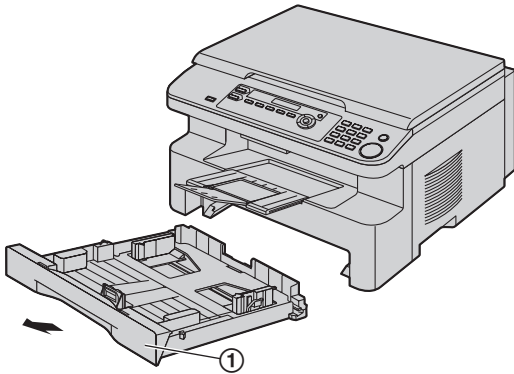

- 2** Before loading a stack of paper, fan the paper to prevent paper jams.

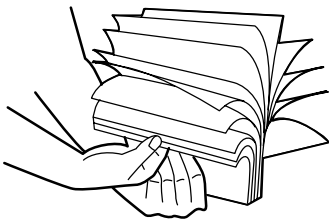

- 3** Load the paper, print-side up (②).

Important:

- **Push and lock the plate (③) in the paper input tray, if it is lifted.**

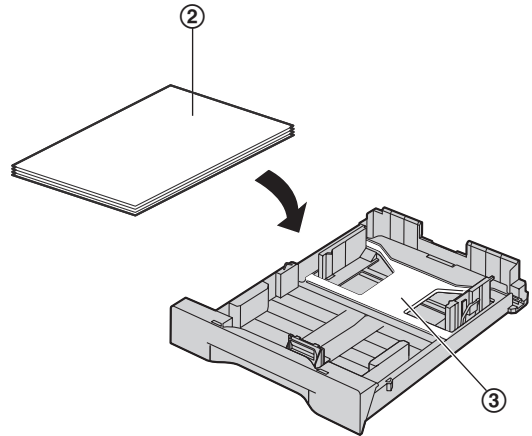

- 4** Adjust the recording paper guides. Pinch the front side of the recording paper guide (④), then slide it to match the paper size mark. Pinch the right side of the recording paper guide (⑤), then slide it to adjust the width to the size of the recording paper.

- Make sure that the recording paper is under the paper limit mark (⑥), and the paper should not be loaded over the snubbers (⑦).

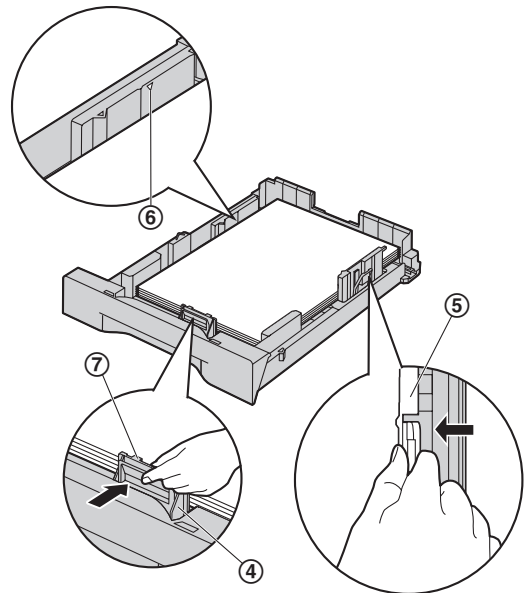

- 5 Insert the paper input tray to the unit, lifting the front part of the tray. Then push it completely into the unit.

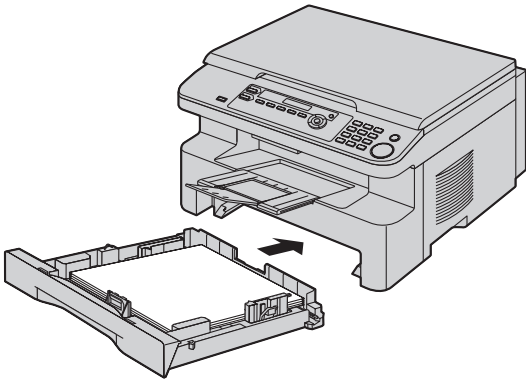

Note:

- If the paper is not loaded correctly, re-adjust the paper guides, or the paper may jam.
- If the paper input tray does not close, the plate in the paper input tray may be lifted. Push the paper and make sure that the paper is laid flat in the paper input tray.

Caution for the paper input tray

- Do not drop the paper input tray.

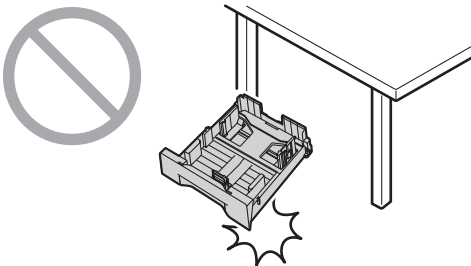

- Hold the paper input tray with both hands when removing or installing. The paper input tray weighs approximately 2 kg when the recording paper is fully installed.

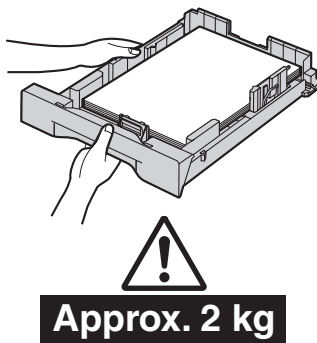

1.8 Handset unit (KX-MB773/KX-MB783 only)

- 1 Connect the handset cord (①).

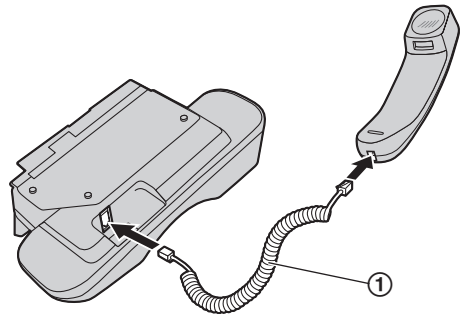

- 2 Connect the handset connector (②).

- Remove the seal from the handset unit connection jack if attached.

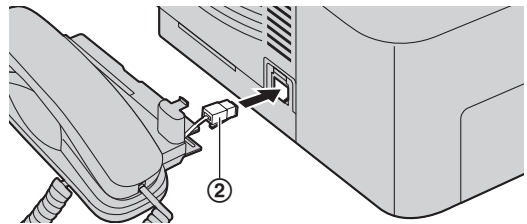

- 3 Insert the tab (③) and rib (④).

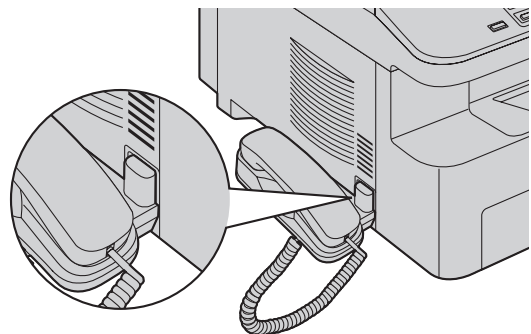
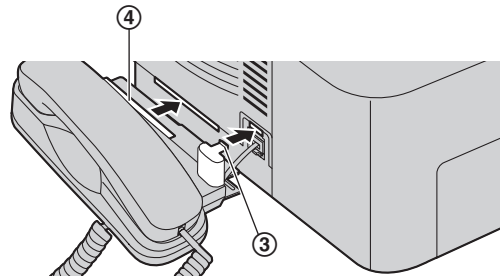

1. Introduction and Installation

Caution:

- When moving the unit, be sure to hold by the grip. Do not hold by the handset unit.

Correct

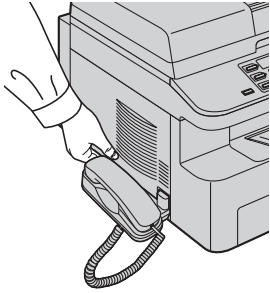

Incorrect

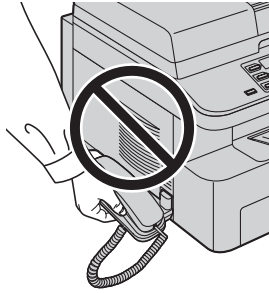

To remove the handset unit

1. Pull the handset unit slightly forward (①), then lift it in the direction of the arrow (②) to remove the rib.

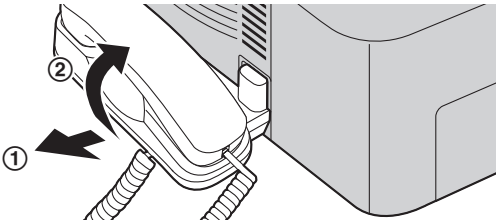

2. Remove the tab (③), then disconnect the handset connector (④).

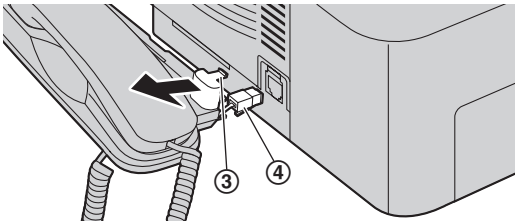

2.1 Connections

Caution:

- When you operate this product, the power outlet should be near the product and easily accessible.
- Be sure to use the telephone line cord included in this unit (KX-MB773/KX-MB783 only).
- Do not extend the telephone line cord (KX-MB773/KX-MB783 only).

- ① Power cord
 - Connect to a power outlet (220–240 V, 50/60 Hz).
- ② Telephone line cord*¹
 - Connect to a single telephone line jack.
- ③ [EXT] jack*¹
 - You can connect an answering machine or an extension telephone. Remove the stopper if attached.
- ④ Answering machine (not included)*¹
- ⑤ Network router/Network hub (not included)*²
 - Also connect networked computers.
- ⑥ To the internet*²
- ⑦ LAN cable (not included)*²
 - To assure continued emission limit compliance, use only shielded LAN cable (category 5 straight cable).

*1 KX-MB773/KX-MB783 only

*2 KX-MB783 only

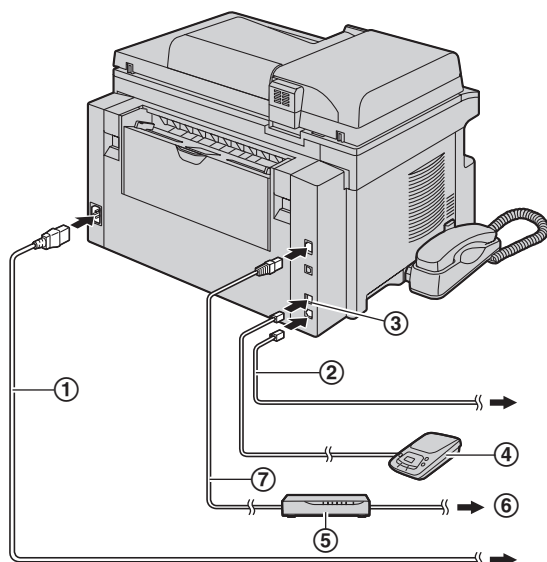

* The pictured model is KX-MB783.

Important notice for the USB connection

- Do NOT connect the USB cable until prompted by the Multi-Function Station (page 28).

Note:

- If any other device is connected to the same telephone line, this unit may disturb the network condition of the device (KX-MB773/KX-MB783 only).
- If you use the unit with a computer and your internet provider instructs you to install a filter (Ⓢ), please connect it as follows (KX-MB773/KX-MB783 only).

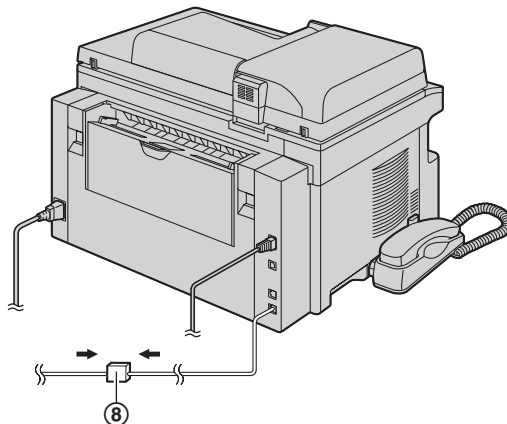

* The pictured model is KX-MB783.

This model is designed to be used in Czech, Hungary and Slovakia according to the location setting feature (KX-MB773EX/KX-MB783EX only). The default setting is Czech. To change the location setting, see page 56 (feature #114).

2.2 Dialling mode (KX-MB773/KX-MB783 only)

If you cannot dial (page 43), change this setting according to your telephone line service.

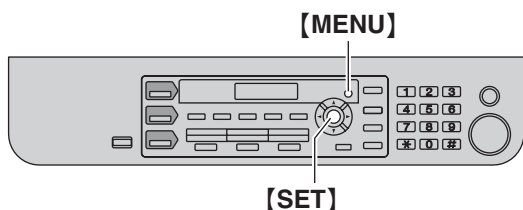

1 [MENU] → [#][1][2][0]

DIALLING MODE
=TONE [▼▲]

2 Press [1] or [2] to select the desired setting.

[1] "PULSE": For rotary/pulse dial service.

[2] "TONE" (default): For tone dial service.

3 [SET]

4 Press [MENU] to exit.

2.3 Selecting the operation mode (Scan/Copy) (Fax: KX-MB773/KX-MB783 only)

You can select the desired mode by pressing one of the following buttons.

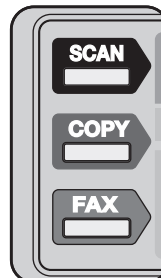

* The pictured model is KX-MB773/KX-MB783.

– [SCAN]: Select this mode when using the unit as a scanner for the computer (page 33).

– [COPY]: Select this mode when using the unit as a copier (page 36).

– [FAX] (KX-MB773/KX-MB783 only): Select this mode when using the unit as a fax machine (page 43).

Note:

- The default operation mode is the copy mode.
- You can change the default operation mode (feature #463 on page 58) and the timer before returning to the default operation mode (feature #464 on page 58) (KX-MB773/KX-MB783 only).

2.4 Setting the original

2.4.1 Using the scanner glass

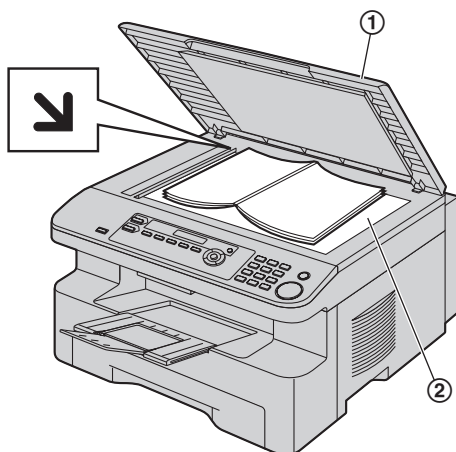

- 1 Open the document cover (①).
- 2 Place the document FACE DOWN on the scanner glass (②), aligning the top left of the document with the corner to which the  mark points.
- 3 Close the document cover.

Note:

- Confirm that there are no documents in the auto document feeder (KX-MB773/KX-MB783 only).
- Place the original onto the scanner glass gently and do not press down too firmly to avoid malfunction.
- If the original is a thick book, do not close the document cover.
- Check that ink, paste or correction fluid has dried completely.
- Effective scanning area is as follows:
 - **Effective scanning area**
 - Shaded area will be scanned.

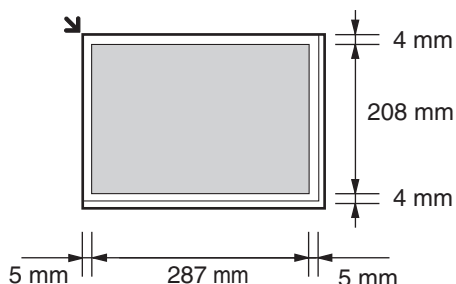

2.4.2 Using the auto document feeder (KX-MB773/KX-MB783 only)

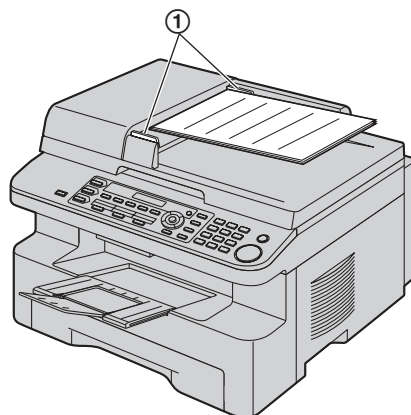

- 1 Insert the document (up to 20 pages) FACE UP into the feeder until a single beep is heard.
- 2 Adjust the width of the document guides (①) to fit the actual size of the document.

Note:

- Confirm that there are no documents on the scanner glass.
- Check that ink, paste or correction fluid has dried completely.
- Remove clips, staples or other fasteners.
- Do not set the following types of documents: (Make a copy of the document using the scanner glass and set the copy instead.)
 - Chemically treated paper such as carbon or carbonless duplicating paper
 - Electrostatically charged paper
 - Badly curled, creased or torn paper
 - Paper with a coated surface
 - Paper with printing on the opposite side that can be seen through the other side, such as newsprint
- The total height of the documents when laid flat, must be less than 4 mm. If the documents exceed the capacity of the auto document feeder, they may fall or cause a jam in the feeder.
- To set a document with a width of less than 210 mm, we recommend using the scanner glass to copy the original document onto A4 or letter-sized paper, then setting the copied document.
- Do not set documents that do not satisfy the requirements of size and weight. Make a copy of the document using the scanner glass and set the copy.
- Available document size, document weight and effective scanning area are as follows:

2. Preparation

Minimum document size

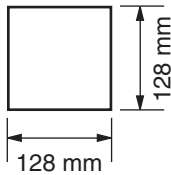

Maximum document size

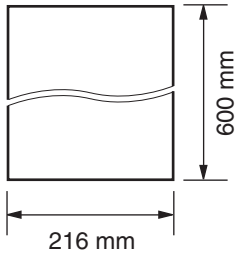

Effective scanning area

- Shaded area will be scanned.

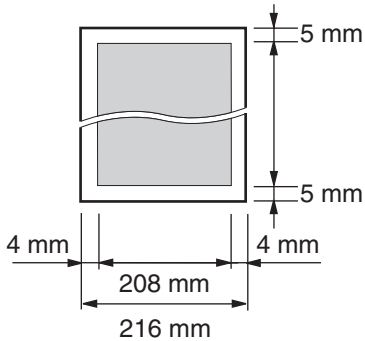

Document weight

- Single sheet:
60 g/m² to 75 g/m²
- Multiple sheets:
60 g/m² to 75 g/m²

2.5 Help function (KX-MB773/KX-MB783 only)

The unit contains helpful information on the following topics which can be printed for reference purposes, as follows:

- "BASIC SETTINGS"
- "FEATURE LIST"
- "DIRECTORY"
- "FAX RECEIVING"
- "COPIER"
- "REPORTS"
- "CALLER ID"

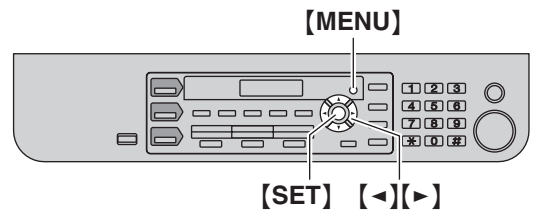

- 1 Press [MENU] repeatedly to display "HELP".
- 2 Press [◀] or [▶] repeatedly to display the desired item. → [SET]
- 3 Press [MENU] to exit.

2.6 Adjusting volume (KX-MB773/KX-MB783 only)

Important:

- Before adjusting volume, set the operation mode to fax mode. If the [FAX] light is OFF, turn it ON by pressing [FAX].

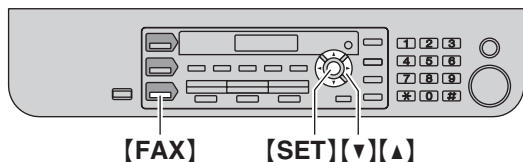

Ringer volume

While the unit is idle, press [▼] or [▲].

- If there are any documents in the document entrance, you cannot adjust the volume. Confirm that there are no documents in the entrance.

To turn the ringer OFF

Press [▼] repeatedly to display "RINGER OFF= OK?".
→ [SET]

- The unit will not ring.
- To turn the ringer back ON, press [▲].

Ringer pattern

- You can select one of 3 ringer patterns (feature #161 on page 57).

Monitor volume

While using the monitor, press [▼] or [▲].

2.7 Date and time (KX-MB773/KX-MB783 only)

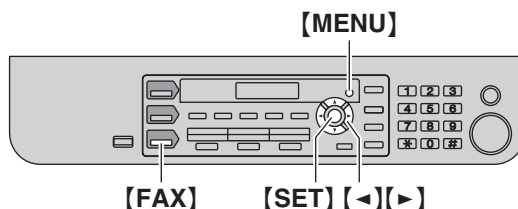

- 1 [MENU] → [#][1][0][1] → [SET]

D:01/M:01/Y:07
TIME: 00:00

- 2 Enter the current date/month/year/hour/minute by selecting 2 digits for each. Press [*] repeatedly to select "AM" or "PM", or 24-hour time entry.

Example: 10 August, 2007 10:15 PM (12 hour clock format)

1. Press [1][0][0][8][0][7][1][0][1][5].

D:10/M:08/Y:07
TIME: 10:15

2. Press [*] repeatedly to select "PM".

- 3 [SET]

- 4 Press [MENU] to exit.

Note:

- The other party's fax machine will print the date and time on the top of each page you send according to your unit's date and time setting.
- After setting the date and time, if the unit is in the copy mode, change it to the fax mode by pressing [FAX]. You can check your unit's date and time setting on the display.

To correct a mistake

Press [◀] or [▶] to move the cursor to the incorrect number, and make the correction.

2. Preparation

2.8 Your logo (KX-MB773/KX-MB783 only)

You can program your logo (name, company name, etc.) so that it appears on the top of each page sent.

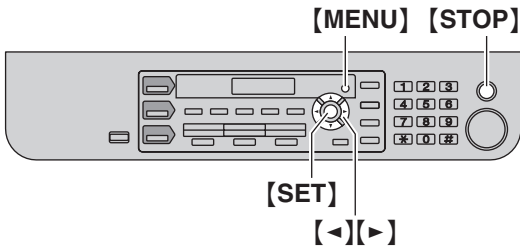

- 1 **[MENU]** → **[*][1][0][2]** → **[SET]**

LOGO=

- 2 Enter your logo, up to 30 characters (see page 68 for character entry). → **[SET]**
- 3 Press **[MENU]** to exit.

To correct a mistake

Press **[←]** or **[→]** to move the cursor to the incorrect character, and make the correction.

- To erase all characters, press and hold **[STOP]**.

2.9 Your fax number (KX-MB773/KX-MB783 only)

You can program your fax number so that it appears on the top of each page sent.

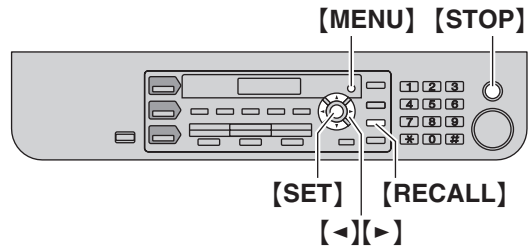

- 1 **[MENU]** → **[*][1][0][3]** → **[SET]**

NO. =

- 2 Enter your fax number, up to 20 digits.
 - To enter a "+", press **[*]**.
 - To enter a space, press **[*]**.
 - To enter a hyphen, press **[RECALL]**.
 - To erase a number, press **[STOP]**.

- 3 **[SET]**

- 4 Press **[MENU]** to exit.

To correct a mistake

Press **[←]** or **[→]** to move the cursor to the incorrect number, and make the correction.

- To erase all numbers, press and hold **[STOP]**.

2.10 Configuring the unit to access the LAN (KX-MB783 only)

You can print documents, scan documents, receive faxes or send faxes using a computer on the LAN. To enable these features, you need to set the IP address, subnet mask, and default gateway for the unit.

Important:

- Consult your network administrator when setting the IP address, subnet mask, and default gateway.

2.10.1 Setting up automatically with a DHCP server

Your situation:

- When only one unit is connected to the LAN.

If your network administrator manages the network with a DHCP (Dynamic Host Configuration Protocol) server, it will automatically assign an IP (Internet Protocol) address, subnet mask, and default gateway to the unit.

- 1 After connecting the LAN cable to the unit and the computer, connect the power cord.
 - The IP address, subnet mask, and default gateway will be set automatically.
- 2 Install Multi-Function Station on the computer that you want to use it with. See page 28 for details.

Note:

- You can connect two or more units and assign IP addresses automatically with a DHCP server, but we recommend assigning static IP addresses manually for each unit to avoid unnecessary trouble.

2.10.2 Setting up manually

Your situation:

- When your network administrator does not manage the network with a DHCP server.
- When two or more units are connected to the LAN.

You need to assign an IP address, subnet mask, and default gateway manually.

- 1 **[MENU]** → **[#][5][0][0]**

DHCP =ENABLED [▼▲]

- 2 Press **[0]** to select "DISABLED" → **[SET]**

- 3 Set each item.

For the IP address:

1. Press **[5][0][1]**.

IP ADDRESS PRESS SET

2. **[SET]** → Enter the IP address of the unit. → **[SET]**

For the subnet mask:

1. Press **[5][0][2]**.

SUBNET MASK PRESS SET

2. **[SET]** → Enter the subnet mask of the network. → **[SET]**

For the default gateway:

1. Press **[5][0][3]**.

DEFAULT GATEWAY PRESS SET

2. **[SET]** → Enter the default gateway of the network. → **[SET]**

- 4 Press **[MENU]** to exit.

- 5 Install Multi-Function Station on the computer that you want to use it with. See page 28 for details.

To correct a mistake in the IP address, subnet mask, or default gateway

Press **[←]** or **[→]** to move the cursor to the incorrect number, and make the correction.

2.10.3 Setting the computer for PC fax reception

You need to select the computer that will be used for receiving faxes.

- Make sure PC fax setting is turned ON beforehand (feature #442 on page 61).

- 1 **[MENU]** → **[#][4][4][3]** → **[SET]**

- 2 Press **[▼]** or **[▲]** repeatedly to select the desired computer. → **[SET]**

- 3 Press **[MENU]** to exit.

Note:

- If the unit is not connected to the LAN, the computer connected to the unit by USB is assigned as the computer for PC fax reception.
- To select the desired computer easily, change the PC name beforehand (page 30).

2.11 Installing Multi-Function Station

2.11.1 Required computer environment

Panasonic Multi-Function Station software enables the unit to carry out the following functions:

- Printing on plain paper and labels
- Scanning documents and converting an image into text with Readiris OCR software
- Scanning from other applications for Microsoft® Windows® that support TWAIN scanning
- Storing, editing or erasing items in directories using your computer (KX-MB773/KX-MB783 only)
- Programming the features using your computer
- Sending, receiving fax documents using your computer (KX-MB773/KX-MB783 only)

To use Multi-Function Station on your computer, the following are required:

Operating System:

Windows 98/Windows Me/Windows 2000/Windows XP/Windows Vista™ operating system

CPU:

Windows 98: Pentium® 90 MHz or faster
Windows Me: Pentium 150 MHz or faster
Windows 2000: Pentium 166 MHz or faster
Windows XP: Pentium 300 MHz or faster
Windows Vista: Recent Processor (x86) 800 MHz or higher processor

RAM:

Windows 98: 24 MB (32 MB or more recommended)
Windows Me: 32 MB (64 MB or more recommended)
Windows 2000: 64 MB or more
Windows XP: 128 MB or more
Windows Vista: 512 MB or more

Other Hardware:

CD-ROM drive
Hard disk drive with at least 150 MB of available space
USB interface
LAN interface (10Base-T/100Base-TX) (KX-MB783 only)

Other:

Internet Explorer® 5.0 or later (KX-MB783 only)

Warning:

- To assure continued emission limit compliance;
 - use only shielded USB cable.
 - use only shielded LAN cable (category 5 straight cable) (KX-MB783 only).

Note:

- Be sure to use a Hi-Speed USB 2.0 certified cable if your computer is equipped with the Hi-Speed USB 2.0 interface.
- USB cable is not included. Please purchase a shielded Type-A male/Type-B male USB cable.

2.11.2 Installing Multi-Function Station on a computer

- **Install Multi-Function Station (CD-ROM) before connecting the unit to a computer with USB cable. If the unit is connected to a computer with USB cable before installing Multi-Function Station, the [Found New Hardware Wizard] dialogue box will appear. Click [Cancel] to close it.**
- **The screenshots shown in these instructions are for Windows XP and are included for reference only.**
- **The screenshots shown in these instructions may differ slightly from those of the actual product.**
- **Software features and appearance are subject to change without notice.**

- 1 Start Windows and exit all other applications.
 - For Windows 2000, Windows XP and Windows Vista users, you must be logged in as an administrator in order to install Multi-Function Station.
- 2 Insert the included CD-ROM into your CD-ROM drive.
 - If the [Select Language] dialogue box appears, select the desired language that you want to use with this software. Click [OK].
 - If the installation does not start automatically: Click [Start]. Choose [Run...]. Type "D:\Install" (where "D:" is the drive letter of your CD-ROM drive). Click [OK].
(If you are not sure what the drive letter is for your CD-ROM drive, use Windows Explorer and look for the CD-ROM drive.)
- 3 [Easy installation]
 - The installation will start.
- 4 When the setup program starts, follow the on-screen instructions.
 - Readiris OCR software (page 34) and Device Monitor (page 69) will also be installed.
- 5 The [Connect Type] dialogue box appears.

For USB connection:

1. [Connect directly with a USB cable.] → [Next]
 - The [Connect Device] dialogue box will appear.

2. Connect the unit with the USB cable (①), then click **[Next]**.

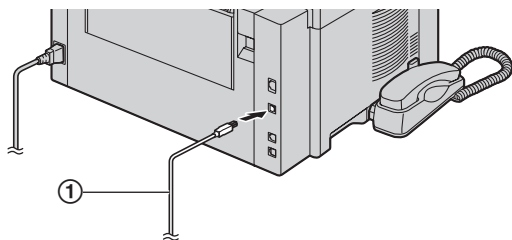

* The pictured model is KX-MB783.

- If the unit is connected to your computer, the model name will be automatically detected.
- You can change the name of the unit if necessary.

3. Click **[Install]**, then follow the on-screen instructions.
 - The files will be copied to your computer.

For LAN connection (KX-MB783 only):

1. **[Connect via the Network.]** → **[Next]**
 - The **[Select a Network Device]** dialogue box will appear.
2. Check **[Select in the searched list]** and select the unit from the list.
 - If the name of the desired unit is not displayed on the list, and the IP address for the unit has been assigned, check **[Direct input]** and enter the IP address.
3. **[Next]**
 - You can change the name of the unit if necessary.
4. Click **[Install]**, then follow the on-screen instructions.
 - The files will be copied to your computer.

Important notice

If you use Windows XP or Windows Vista, a message may appear after connecting the unit with the USB cable. This is normal and the software will not cause any difficulties with your operating system. You can continue the installation with no problem. This kind of message is displayed:

- **For Windows XP users**
“The software you are installing for this hardware has not passed Windows Logo testing to verify its compatibility with Windows XP.”
- **For Windows Vista users**
“Would you like to install this device software?”

To view or install the operating instructions in the CD-ROM

1. Start Windows and insert the included CD-ROM into your CD-ROM drive.
2. Click **[Operating Instructions]**, then follow the on-screen instructions to view or install the operating instructions in PDF format.

- Adobe® Reader® is required to view them.

Note:

- If the screen prompts to insert the CD-ROM for the operating system when installing Multi-Function Station, insert it into your CD-ROM drive.
- If you install the operating instructions, you can view it anytime from **[?]** on the Multi-Function Station launcher.

To use another unit with the computer

You need to add the printer driver for each unit, as follows.

[Start] → **[All Programs]** or **[Programs]** → **[Panasonic]** → the unit's name → **[Add Printer Driver]**. Then follow the on-screen instructions.

Note:

- You cannot connect more than one unit to the same computer at the same time.

To modify the software

You can select the components to install anytime after the installation.

For Windows 2000, Windows XP and Windows Vista users, you must be logged in as an administrator in order to modify Multi-Function Station.

1. Start Windows and insert the included CD-ROM into your CD-ROM drive.
2. **[Start]** → **[All Programs]** or **[Programs]** → **[Panasonic]** → the unit's name → **[Uninstall or Modify]** → **[Modify]** → **[Next]**. Then follow the on-screen instructions.

To uninstall the software

For Windows 2000, Windows XP and Windows Vista users, you must be logged in as an administrator in order to uninstall Multi-Function Station.

1. **[Start]** → **[All Programs]** or **[Programs]** → **[Panasonic]** → the unit's name → **[Uninstall or Modify]**
2. **[Uninstall]** → **[Next]**. Then follow the on-screen instructions.

Note:

- If you want to uninstall each component, select **[Modify]** and click **[Next]** in step 2. Then follow the on-screen instructions.

2.12 Starting Multi-Function Station

[Start] → [All Programs] or [Programs] → [Panasonic] → the unit's name → [Multi-Function Station]

- Multi-Function Station will appear.



* The pictured screenshot is for KX-MB773/KX-MB783.

[Scan] (page 35)

- To scan and display the scanned images.
- To scan and create an image file.
- To scan and send by e-mail.
- To scan and convert an image into editable text data.

[PC FAX] (KX-MB773/KX-MB783 only)

- To send a document created on the computer (page 47).
- To display a document received on the computer (page 52).

[Remote Control] (page 69)

- To program the features.
- To store, edit or erase items in directories.*¹
- To view items in the journal report or Caller ID list.*¹
- To store caller information into directories.*¹
- To store or erase items for broadcast transmission.*¹

[Utilities]

- To start Multi-Function Viewer (page 35).
- To start Device Monitor (page 69).
- To start OCR application (page 34).
- To start the embedded web (page 55, 69) (KX-MB783, LAN connection only).

[Settings] (page 30)

- To change the general settings.
- To change the settings for scanning.

[?]

- For detailed instructions on Multi-Function Station.
- To view operating instructions.

[i]

- To display usage tips.

[i]

- To display information about Multi-Function Station.

*1 KX-MB773/KX-MB783 only

Note:

- You can confirm if the unit is connected to your computer on Device Monitor (page 69).
- Computer features (printing, scanning, etc.) may not function properly in the following situations:
 - When the unit is connected to a computer that was custom-built by the user.
 - When the unit is connected to the computer via a PCI card or other expansion card.
 - When the unit is connected to another piece of hardware (such as a USB hub or interface adapter) and not connected directly to the computer.

To change the settings

You can change the settings for Multi-Function Station beforehand.

1. Select [Settings] from Multi-Function Station.
2. Click the desired tab and change the settings. → [OK]

[General]

- Launcher display: To select the display type of the launcher.
- OCR Path: To select the OCR software.
- PC name list up (KX-MB783, LAN connection only): To select whether or not your computer name is displayed on the unit.
- PC name (KX-MB783, LAN connection only): The computer name that will be displayed on the unit.

[Scan]

- Save to: To select the folder where the scanned image will be saved.
- Viewer/File/E-Mail/OCR/Custom: To change scanning settings for Multi-Function scan application.

Note:

- Assign a unique name for the [PC name] to avoid overlapping, or the scanned image may be sent to an undesired computer.

To select the default E-mail software

The default E-mail software is used when using "4.1.3 Scan to E-mail", page 33.

You can select the default E-mail software as follows.

For Windows XP:

1. [Start] → [Control Panel] → [Internet Options] → [Programs] → [E-mail]
 2. Select the desired MAPI-compliant E-mail software such as [Outlook Express], etc. → [OK]
- These steps may vary depending on your operating system.

3.1 Printing from Windows applications

You can print a file created in a Windows application. For example, to print from WordPad, proceed as follows.

- 1 Open the document you want to print.
- 2 Select **[Print...]** from the **[File]** menu.
 - The **[Print]** dialogue box will appear.
For details about the **[Print]** dialogue box, click **[?]**, then click the desired item.

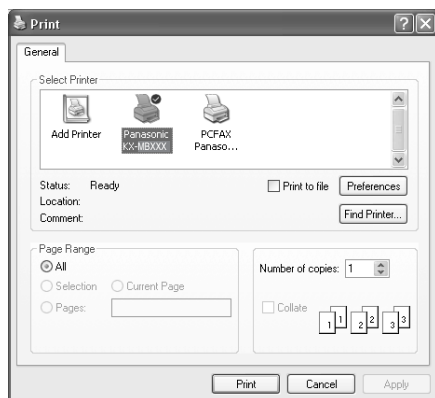

Note:

- For Microsoft PowerPoint®, select **[Colour]** or remove the check next to **[Greyscale]** in the print dialogue so that coloured text will be printed in greyscale.

- 3 Select the unit's name as the active printer.
 - If you have changed the name of the unit when installing, select that name from the list.
 - To change the printer settings, proceed as follows.

For Windows 98/Windows Me:

Click **[Properties]**, then click the desired tab. Change the printer settings, then click **[OK]**.

For Windows 2000:

Click the desired tab and change the printer settings.

For Windows XP/Windows Vista:

Click **[Preferences]**, then click the desired tab. Change the printer settings, then click **[OK]**.

- 4 Click **[Print]** or **[OK]**.
 - The unit will start printing.

Note:

- To stop printing from the unit, see page 69.
- To load paper, see page 18, 32.
- When using the manual input tray, load the recording paper after step 4.
- For details about the paper specifications, see page 93.

- If a printing error occurs, the Device Monitor will be started automatically and display the error information.

Setting the printer properties

You can change the printer setting in step 3. We recommend that you test paper (especially special sizes and types of paper) on the unit before purchasing large quantities.

You can change or display the settings on the following tabs.

[Basic] Paper size, media type, page per sheet, etc.

[Output] Number of prints, collate, etc.

[Quality] Resolution, contrast, toner save feature, etc.

[Effects] Watermark, overlay.

[Profile] Saving the desired settings, selecting the saved settings, etc.

[Support] Version information.

Note:

- When printing from a computer, the toner save feature on the **[Quality]** tab overrides the unit's toner save setting (feature #482 on page 58).

3. Printer

3.1.1 Using the manual input tray

You can print on plain paper and labels. The manual input tray is used only for printing with the computer and can hold one page at a time. When printing multiple pages, add a next page after the first page has been fed into the unit.

- Please refer to page 93 for information on recording paper.

Load the recording paper after you have started printing with the computer.

- 1 Adjust the width of the guides (①) to the size of the recording paper.
- 2 Insert the paper, print-side down (②) until the unit grasps the paper and a single beep is heard.

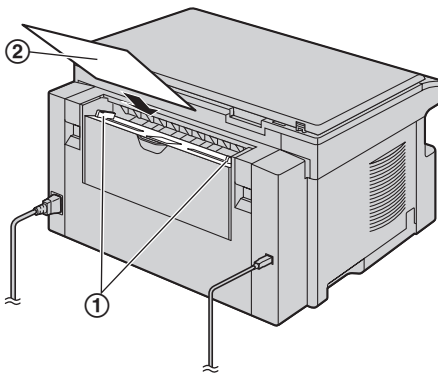

Note:

- If the paper is not inserted correctly, re-adjust the paper, or the paper may jam.
- Make sure the unit grasps the recording paper as specified in step 2. The display shows the following.

PAPER IN TRAY #2
FOR PC PRINTING

- To use the manual input tray, you must change the paper source in the [Basic] tab when setting the printer properties (page 31). You can also select the desired media type.

To print on labels

Use labels designed for laser printing. We recommend the following:

Avery®

5160/5161/5162/5163/5164/5165/5167/5168

XEROX®

LWH100/LWH110/LWH120/LWH130/LWH140

- Use the manual input tray to print labels.
- Load label sheets one page at a time for printing, print-side down.
- Remove each label after printing.
- Do not use the following types of labels:
 - Labels that are wrinkled, damaged or separated from the backing sheet.

- Any sheet of labels that has spaces in it where some of the labels have been removed.
- Labels that do not completely cover the backing sheet as follows.

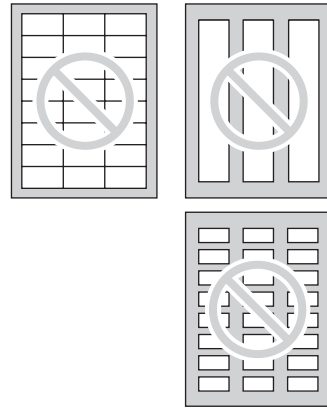

4.1 Scanning from the unit (Push Scan)

You can easily scan the document by operating the operation panel on the unit. Select following scanning modes depending on the way to use the scanned image.

- Viewing using Multi-Function Viewer (Viewer)
- Saving as a file to your computer (File)
- Sending as an attached file to e-mail destination (E-Mail)
- Using OCR software (OCR)

Note:

- You can set the desired scan mode for push scan beforehand (feature #493 on page 64).
- The scanned image will be automatically saved in the folder selected by **[Settings]** window.
- When scanning a document, we recommend using the scanner glass rather than the auto document feeder for better results (KX-MB773/KX-MB783 only).
- Do not open the document cover when scanning a document with the auto document feeder (KX-MB773/KX-MB783 only).

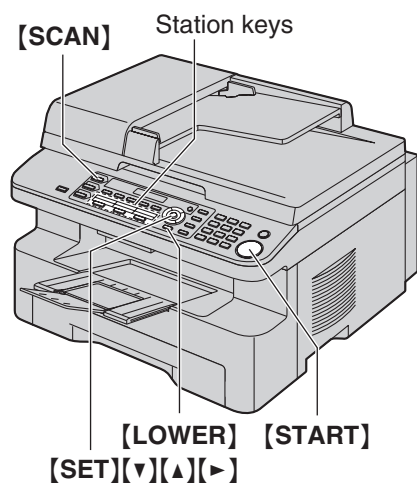

* The pictured model is KX-MB773/KX-MB783.

4.1.1 Scan to Multi-Function Viewer

- 1 Set the original (page 23).
- 2 **[SCAN]**
- 3 Press **[▼]** or **[▲]** repeatedly to select “VIEWER”. → **[SET]**
- 4 **For USB connection:**
Press **[▼]** or **[▲]** repeatedly to select “USB HOST”. → **[SET]**

For LAN connection (KX-MB783 only):

Press **[▼]** or **[▲]** repeatedly to select the computer that you want to send the scanned image. → **[SET]**

- 5 If necessary, change the scanning settings (scan type / resolution / file format / brightness / contrast / scan size). Press **[▶]**, press **[▼]** or **[▲]** repeatedly to select the desired setting. → **[SET]** → **[START]**
 - The scanned image will be displayed in the **[Multi-Function Viewer]** window after scanning. However, when you select PDF as a file format, the software that is associated to open PDF file will start.

Note:

- To stop scanning, see page 69.
- You can save the images in TIFF, JPEG, BMP or PDF formats.
- See page 23 for document requirements.

4.1.2 Scan to save as a file

- 1 Set the original (page 23).
- 2 **[SCAN]**
- 3 Press **[▼]** or **[▲]** repeatedly to select “FILE”. → **[SET]**
- 4 **For USB connection:**
Press **[▼]** or **[▲]** repeatedly to select “USB HOST”. → **[SET]**

For LAN connection (KX-MB783 only):

Press **[▼]** or **[▲]** repeatedly to select the computer that you want to send the scanned image. → **[SET]**

- 5 If necessary, change the scanning settings (scan type / resolution / file format / brightness / contrast / scan size). Press **[▶]**, press **[▼]** or **[▲]** repeatedly to select the desired setting. → **[SET]** → **[START]**
 - The scanned image will be automatically saved in the folder selected by **[Settings]** window. To change the folder, see page 30.

Note:

- To stop scanning, see page 69.
- You can save the images in TIFF, JPEG, BMP or PDF formats.

4.1.3 Scan to E-mail

You can send the scanned image as attached file to an e-mail using e-mail software in your computer.

- 1 Set the original (page 23).
- 2 **[SCAN]**
- 3 Press **[▼]** or **[▲]** repeatedly to select “E-MAIL”. → **[SET]**
- 4 **For USB connection:**
Press **[▼]** or **[▲]** repeatedly to select “USB HOST”. → **[SET]**

For LAN connection (KX-MB783 only):

Press **[▼]** or **[▲]** repeatedly to select the computer that you want to send the scanned image. → **[SET]**

- 5 If necessary, change the scanning settings (scan type / resolution / file format / brightness / contrast /

4. Scanner

scan size). Press **[▶]**, press **[▼]** or **[▲]** repeatedly to select the desired setting. → **[SET]** → **[START]**

- The e-mail software will automatically start and the scanned image will be attached to a new e-mail message.

Note:

- To stop scanning, see page 69.
- You can save the images in JPEG or PDF formats.

To send the scanned image via e-mail server (KX-MB783, LAN connection only)

You can send the scanned image as an attachment without using e-mail software. To select the e-mail destination easily, register e-mail addresses using the web browser beforehand (page 64).

Important:

- **Program the SMTP server setting beforehand (see page 67).**

1. Set the original (page 23).

2. **[SCAN]**

3. Press **[▼]** or **[▲]** repeatedly to select “**E-MAIL**”. → **[SET]**

4. Press **[▼]** or **[▲]** repeatedly to select “**E-MAIL SERVER**”. → **[SET]**

5. Enter the destination e-mail address.

Using stations 1-3:

Press the desired station key.

Using stations 4-6:

Press **[LOWER]**, then press the desired station key.

Using navigator key:

Press **[▼]** or **[▲]** repeatedly to select the desired destination.

Using dial keypad:

Press **[SET]**, then enter the e-mail address using the dial keypad (page 68).

6. **[SET]**

7. If necessary, change the scanning settings. Press **[▶]**, press **[▼]** or **[▲]** repeatedly to select the desired setting. → **[SET]** → **[START]**

Note:

- If you select black/white for the scan type, you can save the images in TIFF or PDF formats.
If you select greyscale or colour for the scan type, you can save the images in JPEG or PDF formats.

4.1.4 Scan to OCR

With OCR software, you can convert an image into text data that can be edited with word processor software. Readiris OCR software can be installed when installing Multi-Function Station.

1 Set the original (page 23).

2 **[SCAN]**

3 Press **[▼]** or **[▲]** repeatedly to select “**OCR**”. → **[SET]**

4 **For USB connection:**

Press **[▼]** or **[▲]** repeatedly to select “**USB HOST**”. → **[SET]**

For LAN connection (KX-MB783 only):

Press **[▼]** or **[▲]** repeatedly to select the computer that you want to send the scanned image. → **[SET]**

5

If necessary, change the scanning settings (scan type / resolution / file format / brightness / contrast / scan size). Press **[▶]**, press **[▼]** or **[▲]** repeatedly to select the desired setting. → **[SET]** → **[START]**

- The scanned image will be displayed in the OCR window after scanning.

Note:

- You can save the images in TIFF, JPEG or BMP formats.
- For detailed instructions about OCR, select **[Help]**.

4.2 Scanning from a computer (Pull Scan)

Note:

- When scanning a document, we recommend using the scanner glass rather than the auto document feeder for better results (KX-MB773/KX-MB783 only).
- Do not open the document cover when scanning a document with the auto document feeder (KX-MB773/KX-MB783 only).

4.2.1 Using Multi-Function scan application

By clicking an application icon, the selected application starts automatically after scanning.

- 1 Set the original (page 23).
- 2 Start Multi-Function Station. → **[Scan]**
- 3 Click the desired application icon.
 - When you click **[Custom]**, the pre-programmed application starts.
 - To cancel scanning while the documents is being scanned, click **[Cancel]**.

Note:

- You can change the scanning settings beforehand for each application (page 30).
- By pointing the application icon, scanning settings can be displayed as tooltip.
- See page 23 for document requirements.

4.2.2 Using Multi-Function Viewer

- 1 Set the original (page 23).
- 2 Start Multi-Function Station.
- 3 **[Utilities]** → **[Viewer]**
 - **[Multi-Function Viewer]** will appear.
- 4 Click the **[Scan]** icon in the **[Multi-Function Viewer]** window.
 - The unit's name dialogue box will appear.
- 5 If necessary, change the scanning settings on your computer.
 - To preview the scanned image, click **[Preview]**. You can drag the frame to specify the scanned area. If you change the scan mode, brightness, contrast setting, etc., click **[Preview]** to refresh the scanned image.
If you use the auto document feeder (KX-MB773/KX-MB783 only), only the first page will be previewed. When you need to refresh the scanned image, set the document to preview again.
- 6 **[Scan]**
 - If you preview the scanned image using the auto document feeder in step 5, set the document

again and click **[Scan]** (KX-MB773/KX-MB783 only).

- The scanned image will be displayed in the **[Multi-Function Viewer]** window after scanning.
- To save the scanned image, select **[Save As ...]** from the **[File]** menu.
- To cancel scanning while the document is being scanned, click **[Cancel]**.

Note:

- You can display images in applications that support TIFF, JPEG, PCX, DCX and BMP formats.
- You can save images in TIFF, JPEG, PCX, DCX, BMP or PDF formats.
- If the **[Select...]** button is displayed in the **[Target Device]**, click the **[Select...]** to select the unit from the list, then click **[OK]**.
The **[Select...]** button will not be displayed when the only one printer driver has been installed.
- You can move, copy and delete a file or page.

4.2.3 Using other applications

Multi-Function Station includes a TWAIN compliant scanner driver. You can also scan using other applications that support TWAIN scanning. For example, proceed as follows.

- 1 Set the original (page 23).
- 2 Start an application that supports TWAIN scanning.
- 3 Select **[Acquire Image...]** from the **[File]** menu.
 - The unit's name dialogue box will appear.
- 4 If necessary, change the scanning settings on your computer. → **[Scan]**
 - The scanned image will be displayed in the application window after scanning.
 - To cancel scanning while the document is being scanned, click **[Cancel]**.

Note:

- Depending on the application used, the appearance may differ slightly.
- If the **[Select...]** button is displayed in the **[Target Device]**, click the **[Select...]** to select the unit from the list, then click **[OK]**.
The **[Select...]** button will not be displayed when the only one printer driver has been installed.

5.1 Making a copy

Illegal copies

- It is unlawful to make copies of certain documents.

Copying certain documents may be illegal in your country. Penalties of fines and/or imprisonment may be imposed on those found guilty. The following are examples of items that may be illegal to copy in your country.

- Currency
- Bank notes and checks
- Bank and government bonds and securities
- Passports and identification cards
- Copyright material or trademarks without the consent of the owner
- Postage stamps and other negotiable instruments

This list is not inclusive and no liability is assumed for either its completeness or accuracy. In case of doubt, contact your legal counsel.

Notice:

- Install your machine near a supervised area to prevent illegal copies from being made.

5.1.1 Using the scanner glass

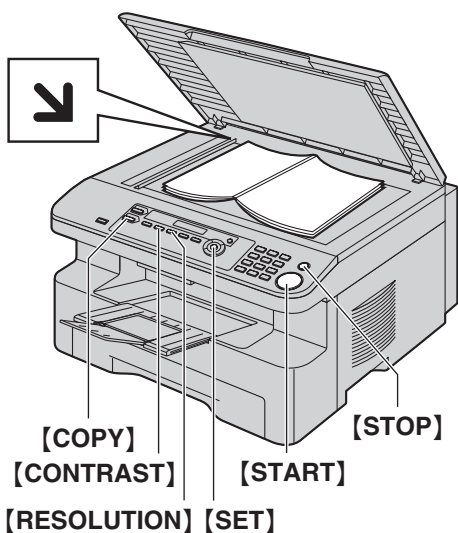

- 1 If the **[COPY]** light is OFF, turn it ON by pressing **[COPY]**.
- 2 Set the original (page 23).
- 3 If necessary, change the resolution and contrast according to the type of document.
 - To select the resolution, see page 36.
 - To select the contrast, see page 36.
- 4 If necessary, enter the number of copies (up to 99).
- 5 **[START]**
 - The unit will start copying.

- 6 After you finish copying, press **[STOP]** to reset the settings you set in step 3 and 4.

Note:

- To stop copying, see page 69.
- You can change the default operation mode (feature #463 on page 58) and the timer before returning to the default operation mode (feature #464 on page 58) (KX-MB773/KX-MB783 only).
- If the **[FAX AUTO ANSWER]** light is ON, the unit can receive faxes automatically even when in the copy mode (KX-MB773/KX-MB783 only).

To select the resolution

1. Press **[RESOLUTION]** repeatedly.
 - “**TEXT/PHOTO**”: For both text and photographs.
 - “**TEXT**”: For text only.
 - “**PHOTO**”: For photographs, shaded drawings, etc.
2. **[SET]**

Note:

- You can change the default resolution (feature #461 on page 63).

To select the contrast

You can adjust this setting depending on the darkness or lightness of the document. 5 levels (light to dark) are available.

Press **[CONTRAST]** repeatedly. → **[SET]**

Note:

- You can hold the previous contrast setting (feature #462 on page 57).

5.1.2 Using the auto document feeder (KX-MB773/KX-MB783 only)

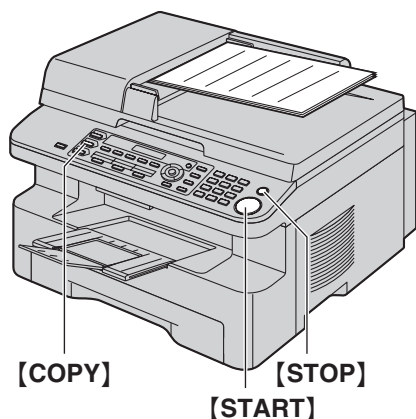

- 1 If the **[COPY]** light is OFF, turn it ON by pressing **[COPY]**.
- 2 Set the original (page 23).
- 3 If necessary, change the resolution and contrast according to the type of document.
 - To select the resolution, see page 36.
 - To select the contrast, see page 36.
- 4 If necessary, enter the number of copies (up to 99).
- 5 **[START]**
 - The unit will start copying.
- 6 After you finish copying, press **[STOP]** to reset the settings you set in step 3 and 4.

Note:

- To stop copying, see page 69.

5.2 More copying features

- Make sure that the **[COPY]** light is ON.

5.2.1 To enlarge/reduce a document

- 1 Set the original (page 23).
- 2 Press **[ZOOM]** repeatedly to select the enlargement / reduction rate that fits the size of your document and recording paper.
 - “**ZOOM =100%**”
 - “**50%**”
 - “**200%**”
 - “**97% (LTR ▶ A4)**”
 - “**94% (A4 ▶ LTR)**”
 - “**83% (LGL ▶ A4)**”
 - “**78% (LGL ▶ LTR)**”
 - If you select “**ZOOM =100%**”, press **[▼]** or **[▲]** repeatedly to change the enlargement / reduction rate by 1% at a time from “**25%**” to “**400%**”.
You can also enter the desired percentage specifically by using the dial keys.
- 3 **[SET]**
- 4 If necessary, enter the number of copies (up to 99).
→ **[START]**
- 5 After you finish copying, press **[STOP]** to reset this feature.

Note:

- Enlargement / reduction copy is not available for quick ID copy feature (page 38), poster feature (page 39) or N in 1 feature (page 39).
- You can hold the previous zoom (enlargement / reduction) setting (feature #468 on page 63).
- **When using the scanner glass**, the unit will only enlarge the right top corner of the document starting from the **↙** mark on the unit.
- **When using the auto document feeder**, the unit will only enlarge the centre of the upper part of the document. To make an enlarged copy of the bottom of the document, turn the document around, and then make a copy (KX-MB773/KX-MB783 only).
- You cannot reduce the whole area of a legal size document (KX-MB263 only).

5. Copier

Example: 150% enlarged copy
Using the scanner glass (①):

Original document Enlarged copy

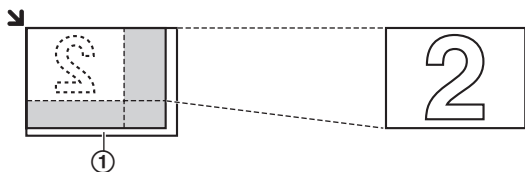

Using the auto document feeder (KX-MB773/KX-MB783 only):

Original document Enlarged copy

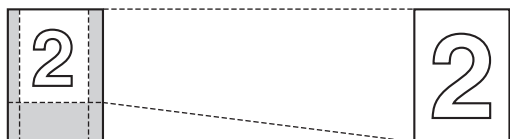

Example: 70% reduced copy
Using the scanner glass (①):

Original document Reduced copy

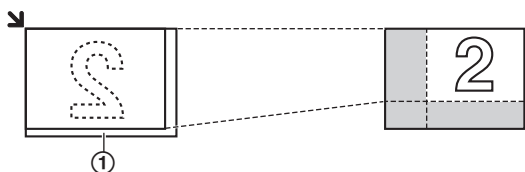

Using the auto document feeder (KX-MB773/KX-MB783 only):

Original document Reduced copy

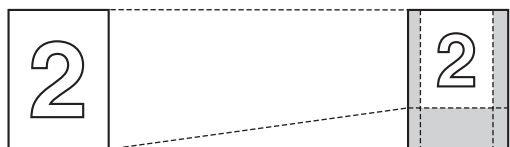



5.2.2 To copy 2-sided documents onto 1 page (Quick ID copy feature) (Scanner glass only)

You can make copies of both sides of 2-sided documents and print them on the same side of paper. The documents will not be reduced to fit the recording paper, so this feature is useful for copying small sized documents such as business cards.

- 1 Set the original (page 23).
 - To make a landscape copy, set the original in landscape direction. To make a portrait copy, set the original in portrait direction.
 - The scanning area changes according to the selected setting in step 3. See the following table for details. The shaded area will be scanned.
- 2 Press **[PAGE LAYOUT]** repeatedly to select "QUICK ID COPY". → **[SET]**
- 3 Press **[▼]** or **[▲]** repeatedly to select the number of original documents from "2 in 1", "4 in 1" or "8 in 1". → **[SET]**
- 4 Press **[▼]** or **[▲]** repeatedly to select the page layout from "LANDSCAPE" or "PORTRAIT". → **[SET]**
- 5 If necessary, enter the number of copies (up to 99). → **[START]**
 - The unit will scan 1 page.
- 6 To continue scanning, place the next document on the scanner glass and press **[SET]**. Repeat this until all the documents are scanned.
 - The unit will start copying.
 - You can press **[START]** anytime to start copying.
- 7 After you finish copying, press **[STOP]** to reset this feature.

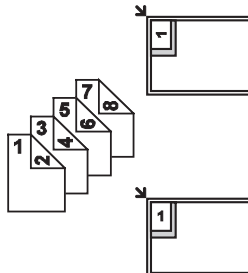
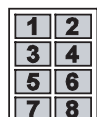
Original document	Page layout
"2 in 1" 	"LANDSCAPE"
	"PORTRAIT"
"4 in 1" 	"LANDSCAPE"
	"PORTRAIT"

Original document	Page layout
"8 in 1" 	"LANDSCAPE"  "PORTRAIT" 

Note:

- You can save the previous page layout setting (feature #467 on page 63).

5.2.3 To make a poster size copy (Poster feature) (Scanner glass only)

You can make copies divided in to 4 ("2 × 2") or 9 ("3 × 3") sections to make enlarged copies of the individual sections. You can then glue them together to make a poster.

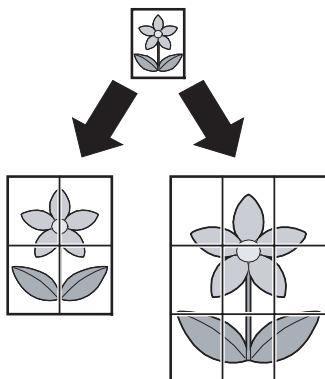

- Set the original (page 23).
- Press **[PAGE LAYOUT]** repeatedly to select "POSTER". → **[SET]**
- Press **[▼]** or **[▲]** repeatedly to select "2 × 2" or "3 × 3". → **[SET]**
- If necessary, enter the number of copies (up to 99). → **[START]**
- After you finish copying, press **[STOP]** to reset this feature.

Note:

- You can save the previous page layout setting (feature #467 on page 63).





5.2.4 To copy several pages onto 1 page (N in 1 feature)

You can save paper by copying 2, 4 or 8 pages onto 1 page. The documents will be reduced to fit the recording paper.

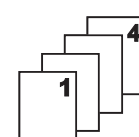

- Set the original (page 23).
 - To make a portrait copy, set the original in portrait direction. To make a landscape copy, set the original in landscape direction.
- Press **[PAGE LAYOUT]** repeatedly to select "N in 1". → **[SET]**
- Press **[▼]** or **[▲]** repeatedly to select the number of original documents from "2 in 1", "4 in 1" or "8 in 1". → **[SET]**
- Press **[▼]** or **[▲]** repeatedly to select the layout from "PORTRAIT" or "LANDSCAPE". → **[SET]**
- If necessary, enter the number of copies (up to 99).
- When using the scanner glass:**
 - [START]**
 - The unit will scan 1 page.
 - Place the next document on the scanner glass and press **[SET]**. Repeat this until all the documents are scanned.
 - The unit will start copying.
 - You can press **[START]** anytime to start copying.

When using the auto document feeder:**[START]**

- After you finish copying, press **[STOP]** to reset this feature.

Original document	Page layout
"2 in 1" 	"PORTRAIT"  "LANDSCAPE" 
"4 in 1" 	"PORTRAIT"  "LANDSCAPE" 

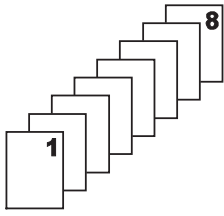
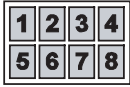
5. Copier

Original document	Page layout
<p>“8 in 1”</p> 	<p>“PORTRAIT”</p>  <p>“LANDSCAPE”</p> 

Note:

- You can save the previous page layout setting (feature #467 on page 63).

5.2.5 To collate multiple copies

The unit can collate multiple copies in the same order as the original document pages.

- 1 Set the original (page 23).
- 2 Press **[COLLATE]** repeatedly to display “ON”.
- 3 **[SET]**
- 4 Enter the number of copies (up to 99).
- 5 **When using the scanner glass:**
 1. **[START]**
 - The unit will scan 1 page.
 2. Place the next document on the scanner glass and press **[SET]**. Repeat this until all the documents are scanned, then press **[START]**.
 - The unit will start copying.

When using the auto document feeder:

[START]

- 6 After you finish copying, press **[STOP]** to reset this feature.

Example: Making 2 copies of a 4-page original document

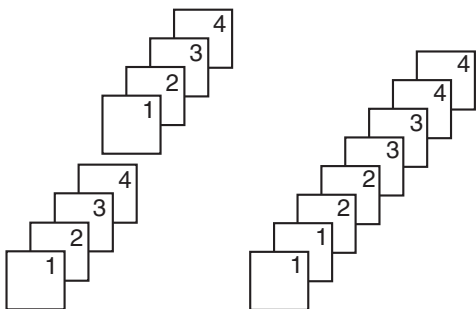

Collated pages

Uncollated pages

Note:

- The unit will store the documents into memory while collating the copies. If memory becomes full while storing, the unit will only print out the stored pages.

During poster feature

1. Set the original and enter necessary settings for poster size copy (steps 2 to 3 on “5.2.3 To make a poster size copy (Poster feature) (Scanner glass only)”, page 39).
2. Press **[COLLATE]** repeatedly to display “ON” and continue copying (steps 3 to 6 on “5.2.5 To collate multiple copies”, page 40).

During N in 1 feature

1. Set the original and enter necessary settings for N in 1 copy (steps 2 to 4 on “5.2.4 To copy several pages onto 1 page (N in 1 feature)”, page 39).
2. Press **[COLLATE]** repeatedly to display “ON” and continue copying (steps 3 to 6 on “5.2.5 To collate multiple copies”, page 40).

Proof set feature (KX-MB773/KX-MB783 only)

To make 1 set of collate copy first, press **[COLLATE]** repeatedly to display “**PROOF SET**” (step 2 on “5.2.5 To collate multiple copies”, page 40). The unit will make 1 set of collate copy and stop temporarily so you can check whether the copy is made as you expected. If the copy is correct, press **[START]** to continue copying. If the copy is not correct, press **[STOP]** and start again from the beginning.

Copy reservation

You can reserve your copy;

- while the unit is printing documents from your computer.
 - while the unit is printing received fax documents (KX-MB773/KX-MB783 only).
1. Set the original (page 23).
 2. While “**PC PRINTING**” or “**PRINTING**” (KX-MB773/KX-MB783 only) is displayed, press **[COPY]**.
 3. Make necessary settings such as number of copies, resolution, zoom features and page layout features.
→ **[START]**
 - “**COPY RESERVED**” will be displayed. The unit will start copying after the current printing job.

6.1 Storing items for the one-touch dial feature and navigator directory

The unit provides the one-touch dial feature (6 items) and navigator directory (100 items).

- Station 1 and 2 can be used alternatively as broadcast keys (page 45).
- Make sure that the **[FAX]** light is ON.

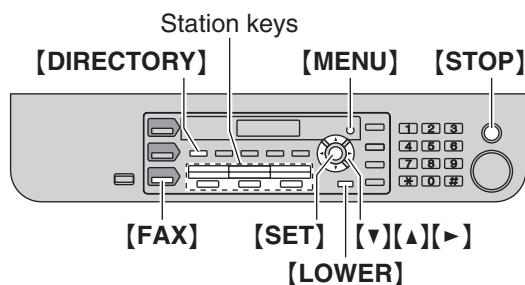

6.1.1 Storing one-touch dial item

- 1 Press **[MENU]** repeatedly to display "DIRECTORY SET".
- 2 Select the desired station key.

For stations 1–2:

1. Press one of the station keys.

Example:

STATION 1	
DIAL MODE	[v^>]

2. **[SET]**

For station 3:

Press the station key.

For stations 4–6:

Press **[LOWER]**, then press one of the station keys.

- 3 Enter the name, up to 16 characters (see page 68 for character entry). → **[SET]**
- 4 Enter the telephone number, up to 32 digits. → **[SET]**
 - To program other items, repeat steps 2 to 4.
- 5 **[STOP]**

Note:

- A hyphen or a space entered in a telephone number counts as 2 digits.

6.1.2 Storing navigator directory items

- 1 Press **[MENU]** repeatedly to display "DIRECTORY SET". → **[>]**
- 2 Enter the name, up to 16 characters (see page 68 for character entry). → **[SET]**

- 3 Enter the telephone number, up to 32 digits. → **[SET]**
 - To program other items, repeat steps 2 to 3.
- 4 **[MENU]**

Note:

- A hyphen or a space entered in a telephone number counts as 2 digits.

6.1.3 Editing a stored item

- 1 **[DIRECTORY]**
- 2 Press **[v]** or **[^]** repeatedly to display the desired item. → **[MENU]** → **[*]**
- 3 Edit the name if necessary. For further details, see the storing procedure on page 41. → **[SET]**
- 4 Edit the telephone number if necessary. For further details, see the storing procedure on page 41. → **[SET]**

6.1.4 Erasing a stored item

- 1 **[DIRECTORY]**
- 2 Press **[v]** or **[^]** repeatedly to display the desired item. → **[MENU]** → **[#]**
 - To cancel erasing, press **[STOP]**.
- 3 **[SET]**

6.2 Making a phone call using one-touch dial feature or navigator directory

Before using this feature, store the desired names and telephone numbers in one-touch dial feature and navigator directory (page 41).

6.2.1 Using one-touch dial feature

- 1 Press **[MONITOR]** or lift the handset.
- 2 Select the desired station key.

For stations 1–3:

Press the desired station key.

For stations 4–6:

Press **[LOWER]**, then press the desired station key.

- The unit will start dialling automatically.

6.2.2 Using the navigator directory

- 1 Press **[DIRECTORY]**.
 - Confirm that there are no documents in the document entrance.
- 2 Press **[v]** or **[^]** repeatedly to display the desired item.
- 3 Press **[MONITOR]** or lift the handset.

6. Telephone (KX-MB773/KX-MB783 only)

- The unit will start dialling automatically.

To search for a name by initial

Example: "LISA"

1. **[DIRECTORY]**
2. Press **[▼]** or **[▲]** to initiate the navigator directory.
3. Press **[5]** repeatedly to display any name with the initial "L" (see page 68 for character entry).
 - To search for symbols, press **[*]**.
4. Press **[▼]** or **[▲]** repeatedly to display "LISA".
 - To stop the search, press **[STOP]**.
 - To dial the displayed party, press **[MONITOR]** or lift the handset.

7.1 Sending a fax manually

7.1.1 Using the scanner glass

By using the scanner glass, you can send a page from booklets or small size paper that cannot be sent with the auto document feeder.

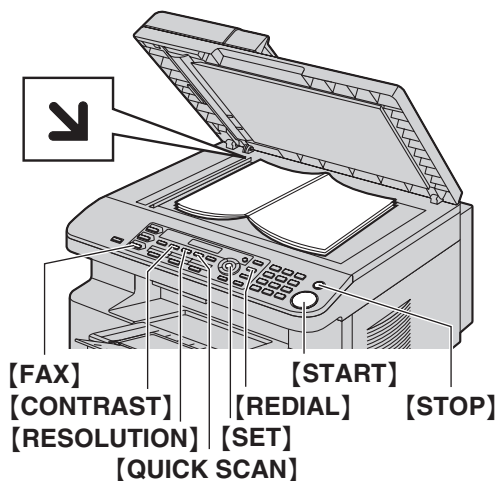

- 1 If the **[FAX]** light is OFF, turn it ON by pressing **[FAX]**.
- 2 Set the original (page 23).
- 3 If necessary, change the resolution and contrast according to the type of document.
 - To select the resolution, see page 43.
 - To select the contrast, see page 43.
- 4 Dial the fax number.
 - To send a single page, skip to step 7.
 - To send multiple pages, go to the next step.
- 5 Press **[QUICK SCAN]** to scan the document into memory.

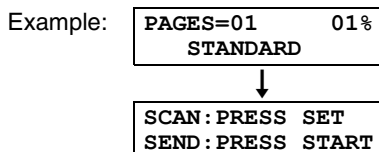

- 6 Place the next page on the scanner glass. → **[SET]**
 - To send more pages, repeat this step.
- 7 **[START]**

Note:

- To stop sending, see page 69.
- You can change the default operation mode (feature #463 on page 58) and the timer before returning to the default operation mode (feature #464 on page 58).

To select the resolution

1. Press **[RESOLUTION]** repeatedly.
 - “**STANDARD**”: For normal-sized characters.
 - “**FINE**”: For small-sized characters.
 - “**SUPER FINE**”: For very small-sized characters.
 - “**PHOTO**”: For photographs, shaded drawings, etc.
2. **[SET]**
 - Using the “**FINE**”, “**SUPER FINE**” and “**PHOTO**” settings will increase transmission time.

To select the contrast

You can adjust this setting depending on the darkness or lightness of the document. 5 levels (light to dark) are available.

Press **[CONTRAST]** repeatedly. → **[SET]**

Note:

- You can hold the previous contrast setting (feature #462 on page 57).

To redial the last number

[RETRIAL] → **[START]**

- If the line is busy, the unit will automatically redial the number 2 or more times.

Note:

- To stop sending, see page 69.

Reserving the fax transmission (Dual Access)

You can reserve the fax transmission even when the unit is just receiving a fax or sending a fax from memory.

- Up to 3 reservations when sending
 - Up to 4 reservations when receiving
1. Set the original during fax reception or fax memory transmission.
 2. Enter the fax number using the dial keypad, one-touch dial or navigator directory.
 3. **When using the scanner glass**, press **[QUICK SCAN]**. The unit will scan 1 page. Place the next document on the scanner glass and press **[SET]**. Repeat this until all the documents are scanned, then press **[START]**.
When using the auto document feeder, press **[START]**.

- If the document exceeds the memory capacity, transmission will be cancelled. You must send the entire document manually.

Printing a sending report

A sending report provides you with a printed record of transmission results. To print sending reports, make sure feature #401 is activated (page 59). For an explanation of error messages, see page 71.

7. Fax (KX-MB773/KX-MB783 only)

Printing a journal report

A journal report provides you with a printed record of the 30 most recent faxes. To print it manually, see page 92. To print it automatically after every 30 new fax transmissions and receptions, make sure feature #402 is activated (page 59). For an explanation of error messages, see page 71.

7.1.2 Using the auto document feeder

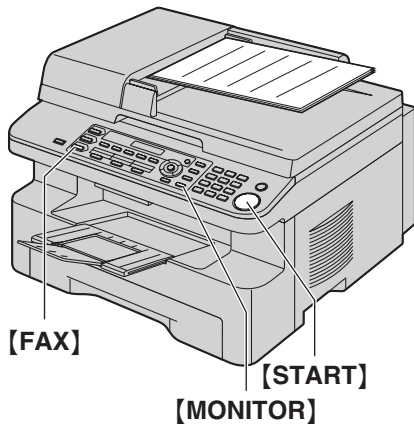

- 1 If the **[FAX]** light is OFF, turn it ON by pressing **[FAX]**.
- 2 Set the original (page 23).
- 3 If necessary, change the resolution and contrast according to the type of document.
 - To select the resolution, see page 43.
 - To select the contrast, see page 43.
- 4 **[MONITOR]**
- 5 Dial the fax number.
- 6 **When a fax tone is heard:**
Press **[START]**.
When the other party answers your call:
Lift the handset and ask them to press their start button. When the fax tone is heard, press **[START]**.

Note:

- After pressing **[START]**, you can replace the handset.
- To stop sending, see page 69.
- See page 23 for document requirements.
- Do not open the document cover when sending a fax with the auto document feeder.

Pre-dialling a fax number

1. Enter the fax number.
2. Set the original. → **[START]**

Sending from memory (Quick scan feature)

1. Set the original.

2. Enter the fax number. → **[QUICK SCAN]**

7.2 Sending a fax using one-touch dial feature and navigator directory

Before using this feature, store the desired names and telephone numbers into one-touch dial feature and navigator directory (page 41).

- Make sure that the **[FAX]** light is ON.

7.2.1 Using the scanner glass

- 1 Set the original (page 23).
- 2 If necessary, change to the desired resolution (page 43) and the desired contrast (page 43).
- 3 Enter the fax number.

Using stations 1–3:

Press the desired station key.

Using stations 4–6:

Press **[LOWER]**, then press the desired station key.

Using navigator directory:

Press **[DIRECTORY]**, then press **[▼]** or **[▲]** repeatedly to display the desired item.

- To send a single page, skip to step 6.
 - To send multiple pages, go to the next step.
- 4 Press **[QUICK SCAN]** to scan the document into memory.
 - 5 Place the next page. → **[SET]**
 - To send more pages, repeat this step.
 - 6 **[START]**

Fax auto redial

If the line is busy or if there is no answer, the unit will automatically redial the number 2 or more times.

Note:

- To stop sending, see page 69.

7.2.2 Using the auto document feeder

- 1 Set the original (page 23).
- 2 If necessary, change to the desired resolution (page 43) and the desired contrast (page 43).
- 3 Enter the fax number using one-touch dial or navigator directory.
- 4 **[START]**

7.3 Broadcast transmission

By storing one-touch dial and navigator directory items (page 41) into the broadcast memory, you can send the same document to multiple parties (up to 20). Your programmed items will remain in the broadcast memory, allowing frequent re-use.

- The broadcast function utilises stations 1–2. The one-touch dial function will be cancelled.
- Make sure that the **[FAX]** light is ON.

7.3.1 Programming items into the broadcast memory

- 1 Press **[MENU]** repeatedly to display “**DIRECTORY SET**”.
- 2 Select the desired broadcast key.

For BROADCAST:

1. **[BROADCAST]**
2. Press **[▼]** or **[▲]** repeatedly to select “**BROADCAST**”.

For MANUAL BROADCAST (using the dial keypad):

1. **[MANUAL BROAD]**
2. Press **[▼]** or **[▲]** repeatedly to select “**MANUAL BROAD**”.

- 3 **[SET]**
- 4 Program items.

Using stations 1–3:

Press the desired station key.

Using stations 4–6:

Press **[LOWER]**, then press the desired station key.

Using navigator directory:

Press **[▼]** or **[▲]** repeatedly to display the desired item. → **[SET]**

Using the dial keypad:

Enter the fax number. → **[SET]**

- The number in brackets indicates the number of registered items.
 - To program other items, repeat this step (up to 20 items).
 - If you have programmed the wrong item, press **[STOP]** to erase the item.
- 5 **[SET]**
 - To program another broadcast key, repeat steps 2 to 5.
 - 6 **[STOP]**

7.3.2 Adding a new item into the broadcast memory

- 1 **[DIRECTORY]**

7. Fax (KX-MB773/KX-MB783 only)

- 2 Press [▼] or [▲] repeatedly to display the desired broadcast memory (“<BROADCAST>” or “<MANUAL BROAD>”). → [MENU] → [✖]
- 3 Press [▼] or [▲] repeatedly to display the desired item you want to add. → [SET]
 - To add other items, repeat this step (up to 20 items).
- 4 [STOP]

Note:

- When adding new items to the MANUAL BROADCAST memory, you can only select stored items.

7.3.3 Erasing a stored item from the broadcast memory

- 1 [DIRECTORY]
- 2 Press [▼] or [▲] repeatedly to display the desired broadcast memory (“<BROADCAST>” or “<MANUAL BROAD>”). → [MENU] → [⏏]
- 3 Press [▼] or [▲] repeatedly to display the desired item you want to erase.
 - To cancel erasing, press [STOP].
- 4 [SET] → [SET] → [STOP]

7.3.4 Sending the same document to pre-programmed parties

To send the same document using the scanner glass

1. Set the original (page 23).
2. If necessary, change to the desired resolution (page 43) and the desired contrast (page 43).
3. Press [BROADCAST] or [MANUAL BROAD].
 - To send a single page, skip to step 5.
 - To send multiple pages, go to the next step.
4. Place the next page. → [SET]
 - To send more pages, repeat this step.
5. [START]
 - After transmission, the unit will automatically print a report (**broadcast sending report**).

Note:

- To stop sending, see page 69.
- If you select “FINE”, “SUPER FINE” or “PHOTO” resolution, the number of pages that the unit can send will decrease.
- If the document exceeds the memory capacity, sending will be cancelled.
- If a party is busy or does not answer, it will be skipped and redialled later 2 or more times.

To send the same document using the auto document feeder

1. Set the original (page 23).

7.4 Sending a computer document as a fax message from your computer

You can access the fax function from a Windows application using Multi-Function Station.

For example, to send a document created from WordPad, proceed as follows.

- 1 Open the document you want to send.
- 2 Select **[Print...]** from the **[File]** menu.
 - The **[Print]** dialogue box will appear.
- 3 Select the PCFAX unit's name as the active printer.
- 4 Click **[Print]** or **[OK]**.
 - The **[Send a Fax]** dialogue box will appear.



- 5 Enter the fax number using the keypad display or the directory.
 - To stop the operation, click **[Cancel]**.
- 6 **[Send]**
 - The document will be sent through the unit from your computer.

Note:

- To stop sending, see page 69.
- If the document exceeds the memory capacity of the unit, sending will be cancelled.
- For details, see the help file by selecting [**?**] from Multi-Function Station.
- Click **[Select...]** to change the active unit.

7.5 Selecting the way to use your fax machine

Depending on your situation, select the way you prefer to use your fax machine.

- Use only as a fax (FAX ONLY mode)
- Use mostly as a telephone (TEL mode)
- Use as a telephone and/or fax (TEL/FAX mode)
- Use with answering machine

7.5.1 Use only as a fax (FAX ONLY mode)

Your situation

You have a separate telephone line just for faxes, or you want to use the unit only for receiving faxes.

Setup

Set the fax machine to FAX ONLY mode (page 48) by pressing **[FAX AUTO ANSWER]** repeatedly.

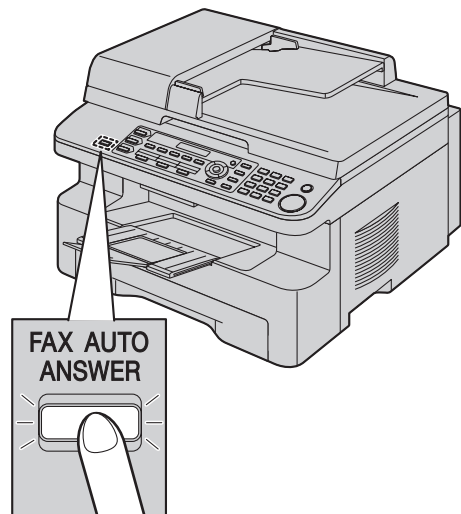

How faxes are received

All incoming calls will be answered as faxes.

7.5.2 Use mostly as a telephone (TEL mode)

Your situation

You want to answer calls by yourself. If a fax call is received, you must receive the fax manually.

Setup

Set the fax machine to TEL mode (page 49) by pressing **[FAX AUTO ANSWER]** repeatedly.

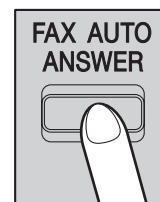

7. Fax (KX-MB773/KX-MB783 only)

Note:

- Make sure feature #404 is set to “TEL” beforehand (page 59).

How to receive phone calls and faxes

You have to answer all calls manually.

To receive a fax document, press **[START]**.

7.5.3 Use as a telephone and/or fax (TEL/FAX mode)

Your situation

You want to answer phone calls yourself and receive faxes automatically without rings.

Setup

Set the fax machine to TEL/FAX mode (page 49) by pressing **[FAX AUTO ANSWER]** repeatedly.



Note:

- Make sure feature #404 is set to “TEL/FAX” beforehand (page 59).

How phone calls and faxes are received

If the call is a phone call, the fax machine will ring.

If a fax calling tone is detected, the fax machine will receive the fax automatically without ringing.

7.5.4 Use with answering machine

Your situation

You want to use the fax machine with an answering machine.

Setup

Connect an external telephone answering machine and set the ring count of the answering machine to less than 4.

- Set the ring count in FAX ONLY mode of the fax machine to more than 4, if you use with auto answer ON.

How to receive calls

When receiving phone calls, the answering machine will record voice messages.

7.6 Receiving a fax automatically – Auto answer ON

7.6.1 Activating FAX ONLY mode

Press **[FAX AUTO ANSWER]** repeatedly to display “FAX ONLY MODE”.

- The **[FAX AUTO ANSWER]** light turns ON.

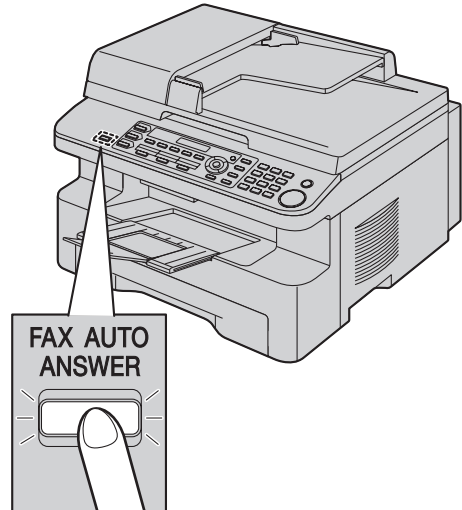

How faxes are received

When receiving calls, the unit will automatically answer all calls and only receive fax documents.

Note:

- The number of rings before a call is answered in FAX ONLY mode can be changed (feature #210 on page 57).

7.7 Receiving a fax manually – Auto answer OFF

7.7.1 Activating TEL mode

- 1 Make sure feature #404 is set to “TEL” beforehand (page 59).
- 2 Press **[FAX AUTO ANSWER]** repeatedly to display “TEL MODE”.
 - The **[FAX AUTO ANSWER]** light turns OFF.

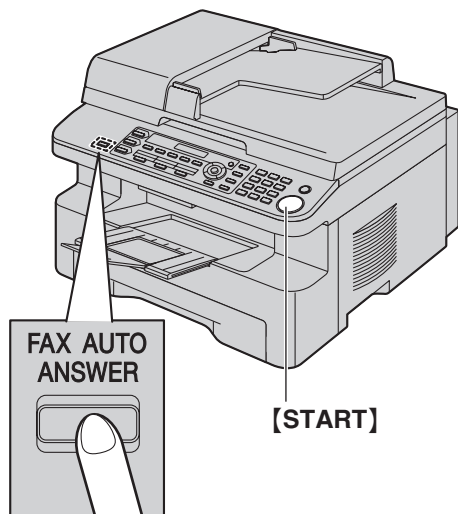

Note:

- If you do not answer the call within 10 rings, the unit will temporarily switch to fax reception. The other party can then send a fax.

How to receive phone calls and faxes with the handset unit

1. Lift the handset to answer the call.
2. When:
 - document reception is required,
 - a fax calling tone (slow beep) is heard, or
 - no sound is heard,
 press **[START]**.
3. Replace the handset.

Note:

- To stop receiving, see page 69.

How to receive faxes with an extension telephone

If you have another telephone connected to the **[EXT]** jack or the same line (extension telephone), you can use the extension telephone to receive faxes.

1. When the extension telephone rings, lift the handset of the extension telephone.
2. When:
 - document reception is required,

- a fax calling tone (slow beep) is heard, or
 - no sound is heard,
- press **[*] [#] [9]** (default fax activation code) **firmly**.

3. Replace the handset.

Note:

- To stop receiving, see page 69.
- To receive fax documents using the extension telephone, make sure remote fax activation is turned ON (feature #434 on page 61) beforehand. The default setting is ON.

7.7.2 Activating TEL/FAX mode

- 1 Make sure feature #404 is set to “TEL/FAX” beforehand (page 59).
- 2 Press **[FAX AUTO ANSWER]** repeatedly to display “TEL/FAX MODE”.
 - The **[FAX AUTO ANSWER]** light turns OFF.
- 3 The ringer volume setting should be ON (page 25).

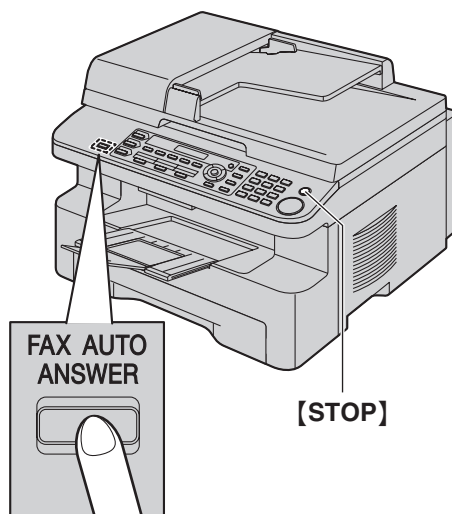

How phone calls and faxes are received

1. “**INCOMING CALL**” will be displayed but the unit will not ring.
2. The unit will wait for the duration of **2 rings** before answering the call.
 - The number of rings is determined by the “**TEL/FAX delayed ring setting**” (feature #212 on page 59).
 - During this time, an extension telephone will ring.
3. The unit will answer the call and try to detect a fax calling tone.

When a fax calling tone is detected

The unit receives the fax automatically without ringing.

When a fax calling tone is not detected

- 1 The unit will ring **3 times**. You may answer the call.

7. Fax (KX-MB773/KX-MB783 only)

- The number of rings is determined by the “**Silent fax recognition ring setting**” (feature #436 on page 61).
 - Callers will hear a ring back tone different from the one generated by the telephone company.
 - When you answer the call using an extension telephone connected to the [EXT] jack, press [STOP] on the unit to talk to the calling party.
- ② If you do not answer the call, the unit will activate the fax function.
- Some fax machines do not generate fax calling tones when sending faxes, therefore the unit will try to receive a fax even if no fax calling tone is detected.

7.8 Using the unit with an answering machine

7.8.1 Setting up the unit and an answering machine

- 1 Connect the answering machine (①).
 - Answering machine is not included.
 - Remove the stopper (②) if attached.

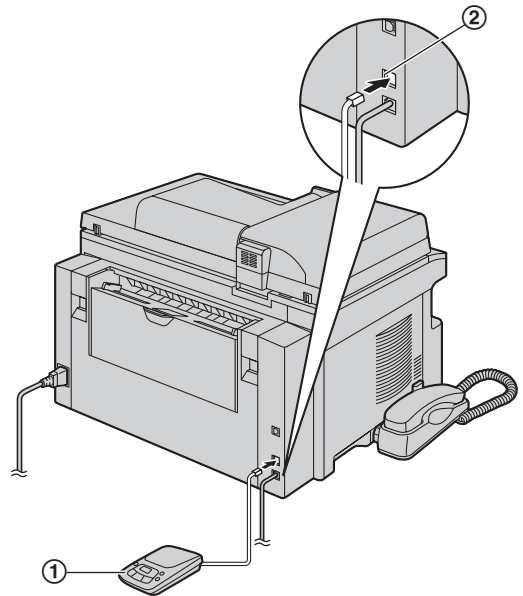

* The pictured model is KX-MB773.

- 2 Set the number of rings on the answering machine to 4 rings or less.
 - This will allow the answering machine to answer the call first.
- 3 Record a greeting message on the answering machine.
 - We recommend you record a message up to 10 seconds long, and not to pause for more than 4 seconds during the message. Otherwise, both machines will not function correctly.
- 4 Activate the answering machine.
- 5 Set the unit to the desired receiving mode (page 48).
 - If you set to FAX ONLY mode, **change the ring setting in FAX ONLY mode to more than 4 (feature #210 on page 57).**
- 6 Make sure each of the following are unique:
 - the remote access code of the answering machine
 - the fax activation code (feature #434 on page 61)

Note:

- If the call is a phone call, the answering machine will record voice messages.

If a fax calling tone is detected, the fax machine will receive a fax automatically.

- Regarding the remote access code for the answering machine, see the operating instructions of the answering machine.

Receiving a voice message and fax document in one call

The caller can leave a voice message and send a fax document during the same call. Inform the caller of the following procedure beforehand.

1. The caller calls your unit.
 - The answering device will answer the call.
2. The caller can leave a message after the greeting message.
3. The caller presses **[*][#][9]** (pre-selected fax activation code).
 - The unit will activate the fax function.
4. The caller presses the start button to send a document.

Note:

- To use this feature, make sure remote fax activation is turned ON (feature #434 on page 61). The fax activation code can also be changed.
- If there is no room left in the memory of your answering machine, the unit may not be able to receive documents. See the operating instructions of the answering machine and erase unnecessary messages.

7.9 Receive polling (retrieving a fax placed on another fax machine)

This feature allows you to retrieve a document from another compatible machine. Therefore you pay for the call.

Make sure that no documents are fed into your unit and that the other party's machine is ready for your call.

- 1 Press **[MENU]** repeatedly to display "POLLING". → **[SET]**
- 2 Dial the fax number. → **[START]**

7.10 Junk fax prohibitor (preventing fax reception from undesired callers)

If you subscribe to Caller ID service (page 53), this feature prevents fax reception from calls that do not show caller information.

Additionally, the unit will not accept faxes originating from numbers that match the ones on a programmable junk fax prohibitor list.

Important:

- **This feature does not work when manual reception is performed.**

7.10.1 Activating the junk fax prohibitor

- 1 Press **[MENU]** repeatedly to display "JUNK FAX PROH.". → **[▶]**
- 2 Press **[▼]** or **[▲]** repeatedly to select "ON". → **[SET]**
- 3 Press **[STOP]** to exit.

7.10.2 Storing undesired callers

You can register up to 20 undesired numbers from the Caller ID list (page 53) if you do not wish to receive faxes from them.

- 1 Press **[MENU]** repeatedly to display "JUNK FAX PROH.".
- 2 Press **[▶]** repeatedly to display "JUNK LIST SET". → **[SET]**
- 3 Press **[▼]** or **[▲]** repeatedly to display the party you wish to prevent fax reception from. → **[SET]**
- 4 Press **[STOP]** 2 times to exit.

To display the junk fax prohibitor list

1. Press **[MENU]** repeatedly to display "JUNK FAX PROH.".
2. Press **[▶]** repeatedly to display "JUNK LIST DISP.". → **[SET]**
3. Press **[▼]** or **[▲]** to display the items on the list.
4. Press **[STOP]** to exit.

To print the junk fax prohibitor list

1. Press **[MENU]** repeatedly to display "JUNK FAX PROH.".
2. Press **[▶]** repeatedly to display "JUNK LIST PRINT". → **[SET]**
3. Press **[STOP]** to exit.

To erase an item from the junk fax prohibitor list

1. Press **[MENU]** repeatedly to display "JUNK FAX PROH.".

7. Fax (KX-MB773/KX-MB783 only)

2. Press **[▶]** repeatedly to display “JUNK LIST DISP.”. → **[SET]**
3. Press **[▼]** or **[▲]** repeatedly to display the desired item. → **[◀]**
 - To cancel erasing, press **[STOP]**, then press **[MENU]**.
4. **[SET]** → **[MENU]**

7.11 Receiving a fax into your computer

You can receive a fax document on your computer. The received fax document is saved as an image file (TIFF-G4 format).

To receive a fax document using your computer, make sure the following features are set beforehand.

- PC fax reception (feature #442 on page 61)
- Computer setting for the PC fax reception (feature #443 on page 61) (KX-MB783, LAN connection only)

1. Press **[FAX AUTO ANSWER]** repeatedly to turn the auto answer setting ON (page 48).
2. Start Multi-Function Station. → **[PC FAX]**
3. When a fax call is received, your computer will receive a document through the unit.

Note:

- You can view, print or transfer the received document using your computer.

Viewing a received document

1. Select **[PC FAX]** from Multi-Function Station.
2. Select **[Received Log]** in **[Communication Log]**.

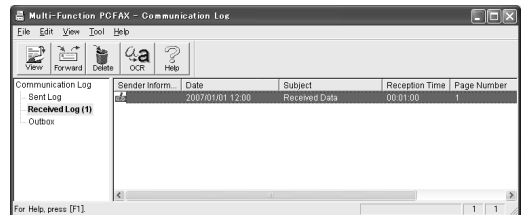

3. Click the item you want to view.
4. Click **[File]** in the menu bar, then select **[View]**, or click **[View]** icon in the toolbar.
 - The received fax will be displayed.

If the unit's memory stores a received fax document

You can load the document into your computer.

1. Select **[PC FAX]** from Multi-Function Station.
2. Select **[Received Log]** in **[Communication Log]**.
3. Click **[File]** in the menu bar. → **[Receive a Fax]**
 - If feature #442 is activated, the received fax document will be automatically transferred to the computer.

8.1 Caller ID service

This unit is compatible with the Caller ID service offered by your local telephone company. To use this unit's Caller ID features, you must subscribe to a Caller ID service.

Important:

- This unit is designed in accordance with the ETS (European Telecommunication Standard) and only supports the basic CLIP (Calling Line Identification Presentation) features.
- This unit will only display the caller's telephone number and name.
- This unit will not support future additional telephone services.
- Depending on the service of the local telephone company, the date/time of the call or the caller's name may not be displayed.

Make sure the following ring count is set to 2 or more rings beforehand.

- FAX ring count (feature #210 on page 57)
- TEL/FAX ring count (feature #212 on page 59)
- The name display service may not be available in some areas. For further information, please contact your telephone company.

8.1.1 How Caller ID is displayed

The calling party's name or telephone number will be displayed after the 1st ring. You have the option of whether or not to answer the call.

The unit will automatically store caller information (name, telephone number and date and time of the call) from the 30 most recent calls. It is possible to view caller information one at a time on the display (page 53) or print the entire Caller ID list (page 92).

- When caller information is received and it matches a telephone number stored in the unit's one-touch dial or navigator directory, the stored name will be displayed.
- If the unit is connected to a PBX (Private Branch Exchange) system, caller information may not be received properly. Consult your PBX supplier.
- If the unit cannot receive caller information, the following will be displayed:
 "OUT OF AREA": The caller dialed from an area which does not provide Caller ID service.
 "PRIVATE CALLER": The caller requested not to send caller information.
 "LONG DISTANCE": The caller made a long distance call.

To confirm caller information by printing the Caller ID list

- To print manually, see page 92.
- To print automatically after every 30 new calls, activate feature #216 (page 57).

8.2 Viewing and calling back using caller information

Important:

- If the area code of the received telephone number is the same as yours, the area code may need to be deleted before calling back. This may only apply to some areas. To edit the number, see page 53.

1 [CALLER ID]

2 Press [▼] to search from the recently received caller information.

- If you press [▲], the display order will be reversed.

3 Press [MONITOR] or lift the handset to return the call.

- To send a fax, see page 43.

To change the way caller information is displayed

Press [CALLER ID] repeatedly after step 2.

Example:

SAM LEE		
11:20	20	Jul. ✓
↑↓		
1345678901		
11:20	20	Jul. ✓

8.2.1 Symbols and operations for caller information

What "✓" means

"✓" on the display means the call has already been viewed or answered.

To stop viewing

Press [STOP].

8.3 Editing a caller's telephone number before calling back/storing

1 [CALLER ID]

2 Press [▼] or [▲] repeatedly to display the desired entry.

3 Press [CALLER ID] to display the telephone number.

4 Press dial key (0 to 9) or [*] to enter the editing mode and edit the telephone number.

5 Press [MONITOR] or lift the handset to call back the edited number.

- The unit will start dialling automatically.
- To send a fax, see page 43.

8. Caller ID (KX-MB773/KX-MB783 only)

Note:

- The edited telephone number will not be saved in the caller information. To save in the directory, see page 54.

To correct a mistake

1. Press [**◀**] or [**▶**] to move the cursor to the incorrect number.
2. Press [**STOP**] to delete the number.
3. Enter the correct number.

To delete a number

Press [**◀**] or [**▶**] to move the cursor to the number you want to delete and press [**STOP**].

8.4 Erasing caller information

8.4.1 Erasing all caller information

- 1 Press [**MENU**] repeatedly to display “**CALLER SETUP**”. → [**SET**]
 - “**CALL LIST ERASE**” will be displayed.
- 2 [**SET**]
 - To cancel erasing, press [**STOP**], then [**MENU**].
- 3 [**SET**] → [**STOP**]

8.4.2 Erasing specific caller information

- 1 [**CALLER ID**]
- 2 Press [**▼**] or [**▲**] repeatedly to display the desired item. → [**◀**] → [**SET**] → [**STOP**]

8.5 Storing caller information

8.5.1 Into the one-touch dial feature and navigator directory

- 1 [**CALLER ID**]
- 2 Press [**▼**] or [**▲**] repeatedly to display the desired item.
- 3 [**MENU**]
- 4 Select the station key or navigator directory.
For stations 1–2:
 1. Press the desired station key.
 2. Press [**▼**] or [**▲**] repeatedly to select “**DIAL MODE**”. → [**SET**] → [**SET**]**For station 3:**

Press the station key. → [**SET**]

For stations 4–6:

Press [**LOWER**], then press the desired station key. → [**SET**]

For navigator directory:

Press [**◀**] or [**▶**]. → [**SET**]

5 [SET]

Note:

- To edit a name or number, see page 41.
- If you assign an item to a station key which already contains an item, the previous item will be replaced.
- Station 1 and 2 can be used alternatively as broadcast keys (page 45).

9.1 Programming

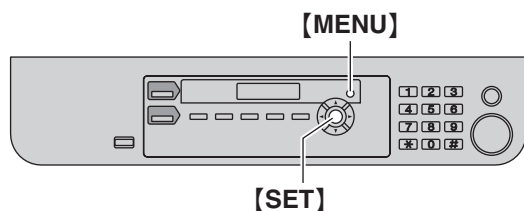

- 1 **[MENU]**
- 2 Press **[\updownarrow]** and the 3-digit code (page 56 to page 66).
- 3 Press the desired selection to display the desired setting.
 - This step may be slightly different depending on the feature.
- 4 **[SET]**
- 5 Press **[MENU]** to exit.

To select features using the web browser (KX-MB783, LAN connection only)

You can change features using the web browser instead of the unit.

1. Start Multi-Function Station. → **[Utilities]** → **[Embedded Web]**
 - You can also access the unit by entering its IP address on the web browser.
2. Select the desired category from the menu bar.
 - [Device Configuration]**: features of the unit
 - [Network Configuration]**: features of the network
3. Type "root" as the user name, then enter the password (feature #155 on page 57). → **[OK]**
4. Select the desired feature tab at the top of the right frame.
5. Change the settings or edit information.
 - This step may be slightly different depending on the feature.
6. **[Submit]**
 - The new data will be transferred to the unit.
7. Close the web browser.

Note:

- The settings displayed in the web browser will be updated by clicking **[Reload]**.

9.2 Basic features

Feature/Code	Selection
Setting the date and time [#][1][0][1] (KX-MB773/KX-MB783 only)	Enter the date and time using the dial keypad. See page 25 for details.
Setting your logo [#][1][0][2] (KX-MB773/KX-MB783 only)	Enter your logo using the dial keypad. See page 26 for details.
Setting your fax number [#][1][0][3] (KX-MB773/KX-MB783 only)	Enter your fax number using the dial keypad. See page 26 for details.
Selecting the language [#][1][1][0] (KX-MB263HX/KX-MB773EX/KX-MB783EX only)	The display and reports will be in the selected language. <ul style="list-style-type: none"> The location setting must also match your location. See feature #114 on page 56. [1] "ENGLISH": English is used. [2] "CZECH" (default): Czech is used. [3] "SLOVAK": Slovak is used. [4] "HUNGARIAN": Hungarian is used. 1. [MENU] → [#][1][1][0] 2. Press [1] to [4] to select the desired language. → [SET] → [MENU]
Setting the location where you use [#][1][1][4] (KX-MB773EX/KX-MB783EX only)	This setting must match your location. <ul style="list-style-type: none"> The language setting is also available (feature #110 on page 56). [1] "CZECH" (default): To use in Czech. [2] "SLOVAKIA": To use in Slovakia. [3] "HUNGARY": To use in Hungary.
Setting the dialling mode [#][1][2][0] (KX-MB773/KX-MB783 only)	[1] "PULSE" [2] "TONE" (default) See page 22 for details.
Setting recall/flash time [#][1][2][1] (KX-MB773/KX-MB783 only)* ¹	The recall/flash time depends on your telephone exchange or host PBX. [0] "900ms" [1] "700ms" [2] "600ms" [3] "400ms" [4] "300ms" [5] "250ms" [6] "200ms" [7] "160ms" [8] "110ms" [9] "100ms" (default) [*] "90ms" [#] "80ms" Note: <ul style="list-style-type: none"> If the unit is connected via a PBX, PBX functions (transferring a call, etc.) might not work correctly. Consult your PBX supplier for the correct setting.
Changing the LCD display contrast [#][1][4][5]	[1] "NORMAL" (default) [2] "DARKER"

Feature/Code	Selection
Changing the password for feature programming via remote operation [#][1][5][5]	<ol style="list-style-type: none"> 1. [MENU] → [#][1][5][5] → [SET] 2. Enter the current password. → [SET] <ul style="list-style-type: none"> • The default password is “1234”. 3. Enter a new 4-digit password using 0–9. → [SET] 4. Enter the new password again. → [SET] → [MENU] <p>Note:</p> <ul style="list-style-type: none"> • If you forget your current password, “0101” can always be entered in step 2 to continue changing the password. • This password is also used for feature programming via web browser (KX-MB783 only).
Setting the ringer pattern [#][1][6][1] (KX-MB773/KX-MB783 only)	<ol style="list-style-type: none"> [1] “A” (default) [2] “B” [3] “C”
Changing the ring count in FAX ONLY mode [#][2][1][0] (KX-MB773EX/KX-MB783EX only)	<ol style="list-style-type: none"> [2] “2” (default) [3] “3” [4] “4” [5] “5” <ul style="list-style-type: none"> • If you are using the unit with an answering machine, set to more than 4 (page 50).
Changing the ring count in FAX ONLY mode [#][2][1][0] (KX-MB773FX/KX-MB783FX only)	<ol style="list-style-type: none"> [1] “1” [2] “2” (default) [3] “3” [4] “4” [5] “5” [6] “6” [7] “7” [8] “8” [9] “9” <ul style="list-style-type: none"> • If you are using the unit with an answering machine, set to more than 4 (page 50).
Setting the Caller ID list to print automatically [#][2][1][6] (KX-MB773/KX-MB783 only)	<ol style="list-style-type: none"> [0] “OFF” (default): The unit will not print the Caller ID list, but will keep records of the information for the last 30 callers. [1] “ON”: The unit will print the Caller ID list automatically after every 30 new calls (page 53).
Setting the recording paper size in the paper input tray [#][3][8][0]	<ol style="list-style-type: none"> [1] “LETTER”: Letter size paper [2] “A4” (default): A4 size paper [3] “LEGAL”: Legal size paper
Setting the waiting time for the power save mode [#][4][0][3]	<p>To set the length of time before the unit enters the power save mode.</p> <ol style="list-style-type: none"> [1] “5min”: 5 minutes [2] “15min” (default): 15 minutes [3] “30min”: 30 minutes [4] “1h”: 1 hour <p>Note:</p> <ul style="list-style-type: none"> • During the power save mode, the unit needs to preheat the fuser unit before printing.
Holding the previous contrast setting [#][4][6][2]	<ol style="list-style-type: none"> [0] “DISABLED” (default): Deactivates this feature. [1] “ENABLED”: The unit will hold the previous setting. <p>Note:</p> <ul style="list-style-type: none"> • The previous setting will be held individually for copying and sending faxes (KX-MB773/KX-MB783 only).

9. Programmable Features

Feature/Code	Selection
Setting the default operation mode [#][4][6][3] (KX-MB773/KX-MB783 only)	To select the default operation mode when the selected time of the mode timer (feature #464) passes. [1] "COPY" (default): Copy mode is selected as default. [2] "FAX": Fax mode is selected as default. Note: <ul style="list-style-type: none">You cannot select the scan mode using this feature.
Setting the default operation mode timer [#][4][6][4] (KX-MB773/KX-MB783 only)	To set the timer before returning to the default operation mode (feature #463). [0] "OFF": Deactivates this feature. [1] "30s": 30 seconds [2] "1min" (default): 1 minute [3] "2min": 2 minutes [4] "5min": 5 minutes
Setting toner save feature [#][4][8][2]	[0] "OFF" (default): Deactivates this feature. [1] "ON": The toner cartridge will last longer. Note: <ul style="list-style-type: none">This feature may lower the print quality by reducing toner consumption.

*1 For KX-MB773FX/KX-MB783FX, the default setting is "700ms".

9.3 Fax features (KX-MB773/KX-MB783 only)

Feature/Code	Selection
Changing the TEL/FAX delayed ring count [#][2][1][2] (KX-MB773EX/KX-MB783EX only)	If you use an extension telephone in TEL/FAX mode, select the desired number of times the extension telephone rings before the unit answers the call. [2] "2" (default) [3] "3" [4] "4" Note: <ul style="list-style-type: none"> • See page 49 for details.
Changing the TEL/FAX delayed ring count [#][2][1][2] (KX-MB773FX/KX-MB783FX only)	If you use an extension telephone in TEL/FAX mode, select the desired number of times the extension telephone rings before the unit answers the call. [1] "1" [2] "2" (default) [3] "3" [4] "4" [5] "5" [6] "6" [7] "7" [8] "8" [9] "9" Note: <ul style="list-style-type: none"> • See page 49 for details.
Printing a sending report [#][4][0][1]	[0] "OFF": Sending reports will not be printed. [1] "ON": A sending report will be printed after every fax transmission. [2] "ERROR" (default): A sending report will be printed only when fax transmission fails.
Setting the journal report to print automatically [#][4][0][2]	[0] "OFF": The unit will not print a journal report, but will keep a record of the last 30 fax transmissions and receptions. [1] "ON" (default): The unit will print a journal report automatically after every 30 new fax transmissions and receptions (page 44).
Changing the receiving mode in the manual answer setting [#][4][0][4]	[1] "TEL" (default): Telephone mode (page 49) [2] "TEL/FAX": Telephone/Fax mode (page 49)
Sending documents overseas [#][4][1][1]	If you cannot send a fax overseas even if the number is correct and the line is connected, activate this feature before sending the fax. This feature improves the reliability by reducing the transmission speed. [0] "OFF": Deactivates this feature. [1] "NEXT FAX": This setting is effective only for the next attempted fax transmission. After transmission, the unit will return to the previous setting. [2] "ERROR" (default): When the previous fax transmission fails and you wish to re-send the document. Note: <ul style="list-style-type: none"> • This feature is not available for broadcast transmission. • Calling charges may be higher than usual.

9. Programmable Features

Feature/Code	Selection
<p>Sending a fax at a specific time [#][4][1][2]</p>	<p>This feature allows you to take advantage of low-cost calling hours offered by your telephone company. This feature can be set up to 24 hours in advance of the desired time.</p> <p>[0] "OFF" (default) [1] "ON"</p> <p>To send a document:</p> <ol style="list-style-type: none"> If the [FAX] light is OFF, turn it ON by pressing [FAX]. Set the original (page 23). If necessary, change to the desired resolution (page 43) and the desired contrast (page 43). [MENU] → [#][4][1][2] Press [1] to select "ON". → [SET] Enter the fax number. <ul style="list-style-type: none"> To enter an item using one-touch dial feature and navigator directory, see step 3 on "7.2.1 Using the scanner glass", page 45. (When using navigator directory, you do not have to press [DIRECTORY] before pressing [v] or [▲].) [SET] Enter the transmission start time. <ul style="list-style-type: none"> If you selected 12-hour time entry (page 25), press [*] repeatedly to select AM or PM. If you selected 24-hour time entry (page 25), the time is set using 24-hour time entry. When using the scanner glass, press [SET]. → [START] When using the auto document feeder, press [SET]. <ul style="list-style-type: none"> The document will be fed into the unit and scanned into memory. The unit will then send the data at the specified time. <p>Note:</p> <ul style="list-style-type: none"> To cancel after programming, press [STOP] while the unit is idle, and then press [SET].
<p>Setting the Error Correction Mode (ECM) [#][4][1][3]</p>	<p>This feature is available when the sending / receiving fax machines are ECM compatible.</p> <p>[0] "OFF": Deactivates this feature. [1] "ON" (default): If there is an error during fax transmission / reception, the unit will support the communication.</p>
<p>Setting the connecting tone [#][4][1][6]</p>	<p>If you often have trouble when sending faxes, this feature allows you to hear connecting tones: fax tone, ring back tone and busy tone. You can use these tones to confirm the status of the other party's machine.</p> <p>[0] "OFF": Deactivates this feature. [1] "ON" (default): You will hear connecting tones.</p> <p>Note:</p> <ul style="list-style-type: none"> If the ring back tone continues, the other party's machine may not be a fax machine or may have run out of paper. Check with the other party. The connecting tone volume cannot be adjusted.
<p>Setting auto reduction feature [#][4][3][2]</p>	<p>To receive a fax document that is longer than your recording paper.</p> <p>[0] "OFF": The unit will print the original size. [1] "ON" (default): The unit will fit received documents onto your recording paper.</p>

Feature/Code	Selection
Changing the fax activation code [#][4][3][4]	<p>If you wish to use an extension telephone to receive faxes, activate this feature and program the activation code.</p> <p>Important:</p> <ul style="list-style-type: none"> • The fax activation code must be different from the code that you programmed on the answering machine. <p>[0] "OFF" [1] "ON" (default)</p> <ol style="list-style-type: none"> 1. [MENU] → [#][4][3][4] 2. Press [1] to select "ON". → [SET] 3. Enter your code from 2 to 4 digits, using 0–9, [*] and [#]. <ul style="list-style-type: none"> • The default code is *#9. • Do not enter "0000". 4. [SET] → [MENU]
Changing the silent fax recognition ring setting [#][4][3][6]	<p>To change the number of times the unit rings while in TEL/FAX mode.</p> <p>[3] "3" (default) [4] "4" [5] "5" [6] "6" [7] "7" [8] "8" [9] "9"</p> <p>Note:</p> <ul style="list-style-type: none"> • See page 49 for details.
Setting the memory reception alert [#][4][3][7]	<p>To alert you with a beeping sound when a received fax document is stored into memory due to some existing problem.</p> <p>[0] "OFF": Deactivates this feature. [1] "ON" (default): You will hear a beeping sound.</p> <p>Note:</p> <ul style="list-style-type: none"> • The slow beeps will continue until you solve the printing problem and make sure the unit is supplied with enough paper to print the stored document.
Setting friendly reception [#][4][3][8]	<p>To receive a fax automatically when you answer a call and hear a fax calling tone (slow beep).</p> <p>[0] "OFF": You have to press [START] for fax reception. [1] "ON" (default): You do not have to press [START] for fax reception.</p>
Receiving a fax into the computer [#][4][4][2]	<p>If you wish to receive a fax into the computer, activate this feature and run [PC FAX] from Multi-Function Station.</p> <p>[0] "OFF": Deactivates this feature. [1] "ALWAYS": If the unit recognizes the connection to the computer, it will transfer a received document to the computer. If the unit cannot recognize the connection, it will store a received document in the memory once, then transfer the data after recognition of the connection. [2] "CONNECTED" (default): If the unit recognizes the connection to the computer, it will transfer a received document to the computer. If the unit cannot recognize the connection, it will print out the data.</p>
Setting the computer for PC fax reception [#][4][4][3] (KX-MB783 only)	<p>To select the computer that will be used for receiving a fax. See page 27 for details.</p>

9. Programmable Features

Feature/Code	Selection
Resetting fax features to their default settings [#][4][5][9]	[0] "NO" (default) [1] "YES" To reset the fax features: 1. [MENU] → [#][4][5][9] 2. Press [1] to select "YES". → [SET] → [SET] → [MENU] Note: <ul style="list-style-type: none">• The PC fax reception (feature #443 on page 27) will not be reset.

9.4 Copy features

Feature/Code	Selection
Changing the default copy resolution [Ⓜ][4][6][1]	To change the default resolution setting for copying. [1] “TEXT/PHOTO”: For documents containing both text and photographs. [2] “TEXT” (default): For documents containing only text. [3] “PHOTO”: For documents containing photographs, shaded drawings, etc.
Holding the previous page layout setting [Ⓜ][4][6][7]	[0] “DISABLED” (default): Deactivates this feature. [1] “ENABLED”: The unit will hold the previous setting.
Holding the previous zoom (enlargement / reduction) setting [Ⓜ][4][6][8]	[0] “DISABLED” (default): Deactivates this feature. [1] “ENABLED”: The unit will hold the previous setting.
Holding the previous collate setting [Ⓜ][4][6][9]	[0] “DISABLED” (default): Deactivates this feature. [1] “ENABLED”: The unit will hold the previous setting.

9.5 PC print features

Feature/Code	Selection
Changing the data timeout setting [Ⓜ][7][7][4]	The unit will automatically print the remaining data in memory when the computer does not send data to the unit during the set time. 1. [MENU] → [Ⓜ][7][7][4] → [SET] 2. Enter the desired data timeout setting from “005” seconds to “600” seconds, using the dial keypad. <ul style="list-style-type: none"> • The default setting is “060” seconds. 3. [SET] → [MENU]

9.6 Scan features

Feature/Code	Selection
<p>Setting the scan mode for Push Scan [#][4][9][3]</p>	<p>[1] “VIEWER” (default): The scanned image will be displayed in the [Multi-Function Viewer] window. [2] “FILE”: The scanned image will be saved as a file. [3] “E-MAIL”: The scanned image will be saved for e-mail attachment. [4] “OCR”: The scanned image will be displayed in the OCR window.</p>
<p>Holding the previous scanning parameter for Push Scan [#][4][9][4]</p>	<p>[0] “DISABLED” (default): Deactivates this feature. [1] “ENABLED”: The unit will hold the previous scan settings for each mode of push scan; scan type, resolution, file format, brightness, contrast, scan size.</p>
<p>SMTP setting for scan to e-mail (via e-mail server) (KX-MB783, LAN connection only)</p>	<p>This feature can be programmed only by the web browser (page 67).</p>
<p>Registering the scan to e-mail destinations (via e-mail server) (KX-MB783, LAN connection only)</p> <ul style="list-style-type: none"> • This feature can be programmed only by the web browser. 	<p>When you send scanned files via e-mail server, you can register e-mail destinations (up to 30 destinations) to the unit using the web browser in advance.</p> <ol style="list-style-type: none"> 1. Start Multi-Function Station. 2. [Utilities] → [Embedded Web] → [Device Configuration] 3. Type “root” as the user name, then enter the password (feature #155 on page 57). → [OK] 4. Select the [SCAN FEATURE] tab. 5. Click [Edit] next to [SCAN TO E-MAIL]. 6. Click [Edit] next to the desired scan to e-mail user. 7. Enter name and e-mail address, and then select the station key number from the drop-down list if necessary. → [Submit] 8. Close the web browser.

9.7 LAN features (KX-MB783 only)

Feature/Code	Selection
LAN setting with a DHCP server [#][5][0][0]	[0] “DISABLED”: Deactivates this feature. [1] “ENABLED” (default): The following will be allocated automatically using a DHCP (Dynamic Host Configuration Protocol) server. <ul style="list-style-type: none"> – IP address – Subnet mask – Default gateway
Setting the IP address for the LAN connection [#][5][0][1]	This feature is available when feature #500 is deactivated. <ol style="list-style-type: none"> 1. [MENU] → [#][5][0][1] → [SET] 2. Enter the IP address of the unit on the LAN using the dial keypad. → [SET] → [MENU]
Setting the Subnet mask for the LAN connection [#][5][0][2]	This feature is available when feature #500 is deactivated. <ol style="list-style-type: none"> 1. [MENU] → [#][5][0][2] → [SET] 2. Enter the subnet mask of the network on the LAN using the dial keypad. → [SET] → [MENU]
Setting the default gateway for the LAN connection [#][5][0][3]	This feature is available when feature #500 is deactivated. <ol style="list-style-type: none"> 1. [MENU] → [#][5][0][3] → [SET] 2. Enter the default gateway of the network on the LAN using the dial keypad. → [SET] → [MENU]
Setting the primary DNS server for the LAN connection [#][5][0][4]	This feature is available when feature #500 is deactivated. <ol style="list-style-type: none"> 1. [MENU] → [#][5][0][4] → [SET] 2. Enter the primary DNS server of the network on the LAN using the dial keypad. → [SET] → [MENU]
Setting the secondary DNS server for the LAN connection [#][5][0][5]	This feature is available when feature #500 is deactivated. <ol style="list-style-type: none"> 1. [MENU] → [#][5][0][5] → [SET] 2. Enter the secondary DNS server of the network on the LAN using the dial keypad. → [SET] → [MENU]
Setting the machine name [#][5][0][7]	<ol style="list-style-type: none"> 1. [MENU] → [#][5][0][7] → [SET] 2. Enter the name of the unit to recognize on the LAN, up to 15 characters (see page 68 for character entry). → [SET] → [MENU] <p>Note:</p> <ul style="list-style-type: none"> • In order to recognize the unit on the LAN, the default name of the unit is assigned automatically. If you change the name, assign the unique name to avoid overlapping.
Displaying the MAC address of the unit [#][5][0][8]	<ol style="list-style-type: none"> 1. [MENU] → [#][5][0][8] → [SET] 2. The MAC address of the unit will be displayed. → [MENU]
Approving users for the LAN connection [#][5][3][2]	[0] “DISABLED” (default): Deactivates this feature. [1] “ENABLED”: The unit will deny/approve access from the pre-programmed IP patterns. Whether to deny or approve, and up to 4 patterns can be programmed using the web browser (page 55).
Setting the IP address automatically for the LAN connection [#][5][3][3]	This feature is available when feature #500 is activated. [0] “DISABLED” (default): Deactivates this feature. [1] “ENABLED”: IP address will be allocated automatically without using a DHCP (Dynamic Host Configuration Protocol) server.

9. Programmable Features

Feature/Code	Selection
Setting HTTPD for the LAN connection [#][5][3][4]	[0] “DISABLED”: Denies access to the web browser. [1] “ENABLED” (default): Allows access to the web browser.

9.8 Network features (KX-MB783, LAN connection only)

These features can be programmed only by using the web browser.

Feature	Tab	Selection
Setting the location where you use this unit	[LAN FEATURE]	Enter the location information of the unit.
SMTP setting for scan to e-mail (via e-mail server)	[E-MAIL FEATURE]	Enter the SMTP server information to send scanned image from the unit via e-mail server. Consult your service provider or network administrator for details.
Setting the error notify feature	[ERROR NOTIFY]	[ENABLED]: The unit will send an e-mail to registered destinations when the printing problem occurs. [DISABLED] (default): Deactivates this feature.
SMTP setting for error notify feature	[ERROR NOTIFY]	Enter the SMTP server information to send an error notify e-mail.
Registering destinations for error notify feature	[ERROR NOTIFY]	Enter the e-mail address to which error notify will be sent, and select the type of problems.

Note:

- See the following sections for details on these related features:
 - Change password (feature #155 on page 57)
 - DHCP mode (feature #500 on page 65)
 - IP address (feature #501 on page 65)
 - Subnet mask (feature #502 on page 65)
 - Default gateway (feature #503 on page 65)
 - DNS server #1 (feature #504 on page 65)
 - DNS server #2 (feature # 505 on page 65)
 - Machine name (feature #507 on page 65)
 - Approved users (feature #532 on page 65)
 - Auto IP (feature #533 on page 65)
 - HTTPD (feature #534 on page 66)

10.1 Character entry (KX-MB773/KX-MB783 only)

The dial keypad is used to enter characters and numbers.

- Press [◀] or [▶] to move the cursor.
- Press dial keys to enter characters and numbers.
- Press [STOP] to erase the character or number highlighted by the cursor. Press and hold [STOP] to erase all characters or numbers.
- To enter another character located on the same dial key, press [▶] to move the cursor to the next space, then press the appropriate dial key.

Keypad	Characters
[1]	1 . _ - [] { } + / = , ` : ; ?
[2]	A B C 2
	a b c 2
[3]	D E F 3
	d e f 3
[4]	G H I 4
	g h i 4
[5]	J K L 5
	j k l 5
[6]	M N O 6
	m n o 6
[7]	P Q R S 7
	p q r s 7
[8]	T U V 8
	t u v 8
[9]	W X Y Z 9
	w x y z 9
[0]	0 @ () < > ! " # \$ % & ¥ * ^ ' →
[*]	To switch between uppercase or lowercase letters.
[RECALL]	Hyphen
[ZOOM]	To insert a space.
[STOP]	To delete a character.

To select characters using [▼] or [▲]

Instead of pressing the dial keys, you can select characters using [▼] or [▲].

1. Press [▼] repeatedly to display the desired character. Characters will be displayed in the following order:
 - ① Uppercase letters
 - ② Number
 - ③ Symbol
 - ④ Lowercase letters
 - If you press [▲], the order will be reversed.
2. Press [▶] to insert the displayed character.
3. Return to step 1 to enter the next character.

10.2 Status of the unit

10.2.1 Using Remote Control

You can easily operate the following functions from your computer.

- Programming the features (page 56)

KX-MB773/KX-MB783 only

- Storing, editing or erasing items in directories (page 41)
- Storing or erasing items for broadcast transmission (page 45)
- Viewing items in the journal report (page 44)
- Storing the journal report as the computer file
- Viewing items in the Caller ID list (page 53)
- Storing caller information into directories (page 54)
- Storing the Caller ID list as the computer file

- 1 Start Multi-Function Station. → **[Remote Control]**
 - The **[Multi-Function Remote Control]** window will appear.

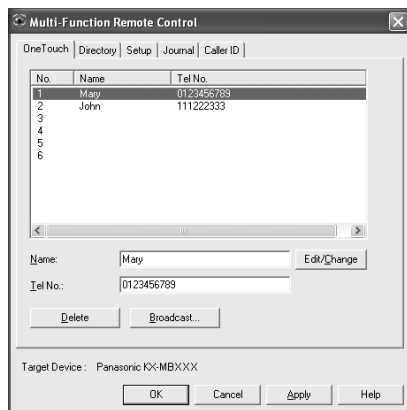

* The pictured screenshot is for KX-MB783.

- 2 Select the desired tab (KX-MB773/KX-MB783 only).
 - The latest data in the unit will be displayed.
- 3 Perform the desired operation.
 - For details about each function, click **[Help]**.
 - To stop the operation, click **[Cancel]**.
- 4 **[OK]**
 - You can also click **[Apply]** to continue the next operation without closing the window.
- 5 Enter the password (feature #155 on page 57). → **[OK]**
 - The new data will be transferred to the unit and the window will close.

Note:

- Some of the features cannot be programmed from your computer.
- For details, see the help file by selecting [?] from Multi-Function Station.

10.2.2 Using Device Monitor

You can confirm the setting information and current status of the unit from your computer.

- 1 Start Multi-Function Station.
- 2 **[Utilities]** → **[Device Monitor]**
 - The **[Device Monitor]** window will appear.
- 3 Confirm the status of the unit.
 - [Status]**: Current status of the unit

Note:

- Additional information (toner and recording paper status, unit information, etc.) will be displayed in **[Status]** tab by clicking **[Advanced Information]**.
- The status of the unit will be updated by clicking **[Refresh]**.
- If a printing error occurs, the Device Monitor will be started automatically and display the error information.
- For details, see the help file by selecting [?] from Multi-Function Station.

10.2.3 Using the web browser (KX-MB783, LAN connection only)

You can confirm the setting information and status of the unit from the web browser.

- 1 Start Multi-Function Station. → **[Utilities]** → **[Embedded Web]**
 - You can also access the unit by entering its IP address on the web browser.
- 2 Select the category from the menu bar.
 - [Status]**: Toner and paper information, etc.
 - [Device]**: Current status of the unit, etc.
 - [Network]**: Network information, etc.
 - When you select **[Device]** or **[Network]**, you can change which features are displayed by clicking the feature tabs at the top of the right frame.
- 3 Confirm the status of the unit.

Note:

- The status of the unit will be updated by clicking **[Reload]**.

10.3 Cancelling the operations

You can cancel the current operation from the unit. You can also select the desired operation to cancel.

- 1 **[STOP]**
 - “USER STOPPED” is displayed.

10. Useful Information

- When “USER STOPPED” is not displayed, go to step 2.

2 To cancel printing:

Press **[STOP]** repeatedly to display “STOP PRINTING?”.

To cancel scanning (KX-MB773/KX-MB783 only):

Press **[STOP]** repeatedly to display “STOP SCANNING?”.

To cancel copying:

Press **[STOP]** repeatedly to display “STOP COPYING?”.

To cancel sending or receiving faxes (KX-MB773/KX-MB783 only):

Press **[STOP]** repeatedly to display “STOP FAX?”.

To cancel broadcast transmission (KX-MB773/KX-MB783 only):

Press **[STOP]** repeatedly to display “BROAD CANCELLED?”.

To cancel fax redialling (KX-MB773/KX-MB783 only):

Press **[STOP]** repeatedly to display “SEND CANCELLED?”.

3 [SET]

11.1 Error messages – Reports (KX-MB773/KX-MB783 only)

If a problem occurs during fax transmission or reception, one of the following messages will be printed on the sending and journal reports (page 43).

Message	Code	Cause & Solution
COMMUNICATION ERROR	40-42 46-72 FF	<ul style="list-style-type: none"> • A transmission or reception error occurred. Try again or check with the other party.
	43 44	<ul style="list-style-type: none"> • A line problem occurred. Connect the telephone line cord to a different jack and try again. • An overseas transmission error occurred. Try using the overseas mode (feature #411 on page 59).
DOCUMENT JAMMED	-----	<ul style="list-style-type: none"> • Remove the jammed document (page 87).
ERROR-NOT YOUR UNIT	53 54 59 70	<ul style="list-style-type: none"> • A transmission or reception error occurred because of a problem with the other party's fax machine. Check with the other party.
JUNK FAX PROH. REJECT	-----	<ul style="list-style-type: none"> • The junk fax prohibitor feature of this unit rejected fax reception.
MEMORY FULL	-----	<ul style="list-style-type: none"> • The memory is full of received documents due to a lack of recording paper or a recording paper jam. Install paper (page 18) or remove the jammed paper (page 82). • If feature #442 is set to "ALWAYS" (page 61), check the connection between the computer and the unit.
NO DOCUMENT / FAILED PICKUP	-----	<ul style="list-style-type: none"> • The document was not fed into the unit properly. Re-insert it and try again.
OTHER FAX NOT RESPONDING	-----	<ul style="list-style-type: none"> • The other party's fax machine is busy or has run out of recording paper. Try again. • The other party's fax machine rings too many times. Send the fax manually (page 43). • The other party's machine is not a fax machine. Check with the other party. • The number you dialled is not in service.
PRESSED THE STOP KEY	-----	<ul style="list-style-type: none"> • [STOP] was pressed and fax communication was cancelled.
THE COVER WAS OPENED	-----	<ul style="list-style-type: none"> • The top cover was opened. Close it and try again.
OK	-----	<ul style="list-style-type: none"> • Fax transmission or reception was successful.

11.2 Error messages – Display

If the unit detects a problem, one or more of the following messages will appear on the display.

Display	Cause & Solution
“CALL SERVICE”	<ul style="list-style-type: none"> There is something wrong with the unit. Contact our service personnel.
“CARRIAGE ERROR”	<ul style="list-style-type: none"> There is something wrong with the carriage sensor. Contact our service personnel.
“CHANGE DRUM”	<ul style="list-style-type: none"> There is something wrong with the drum unit. Replace the drum unit and the toner cartridge.
“CHECK DOCUMENT”	<ul style="list-style-type: none"> The document was not fed into the unit properly. Remove the document, then press [STOP] to clear the message. Re-insert the document. If misfeeding occurs frequently, clean the document feeder rollers (page 91) and try again.
“CHECK DRUM”	<ul style="list-style-type: none"> The drum unit is not inserted properly. Re-insert it correctly (page 13).
“CHECK PAPER #1”	<ul style="list-style-type: none"> Recording paper is not installed or the paper input tray has run out of paper. Install paper (page 18). Recording paper was not fed into the unit properly. Re-insert the recording paper (page 86). The paper input tray is not installed or is not inserted completely. Insert the paper input tray into the unit.
“CHECK PICK UP INPUT TRAY #2”	<ul style="list-style-type: none"> Recording paper was not fed into the unit properly. Re-insert the recording paper (page 86).
“CHECK REAR COVER”	<ul style="list-style-type: none"> The manual input tray (rear cover) is open. Close it. A recording paper jam occurred near the manual input tray (rear cover). Remove the jammed paper (page 82).
“DIRECTORY FULL”	<ul style="list-style-type: none"> There is no space to store new items in navigator directory. Erase unnecessary items (page 41).
“DRUM LIFE LOW REPLACE SOON”	<ul style="list-style-type: none"> The drum life is near to an end. Replace the drum unit as soon as possible.
“FAX IN MEMORY”	<ul style="list-style-type: none"> The unit has a document in memory. See the other displayed message instructions to print out the document. For fax memory capacity, see page 92. If feature #442 is set to “ALWAYS” (page 61), check the connection between the computer and the unit.
“KEEP COPYING”	<ul style="list-style-type: none"> Copying has stopped due to a recording paper jam. See the other displayed message instructions to continue copying.
“LOW TEMP.”	<ul style="list-style-type: none"> The inside of the unit is extremely cold and cannot be operated. Use the unit in a warmer area. While the unit cannot be operated, the received documents are temporarily stored into the memory, and will be printed out automatically when the unit warms up.
“MEMORY FULL”	<ul style="list-style-type: none"> When performing memory transmission, the document being stored exceeded the memory capacity of the unit. Send the entire document manually. When making a copy, the document being stored exceeded the memory capacity of the unit. Press [STOP] to clear the message. Divide the document into sections.
“MODEM ERROR”	<ul style="list-style-type: none"> There is something wrong with the unit’s modem. Contact our service personnel.

Display	Cause & Solution
"NO FAX REPLY"	<ul style="list-style-type: none"> ● The other party's fax machine is busy or has run out of recording paper. Try again.
"OUT OF PAPER INPUT TRAY #2"	<ul style="list-style-type: none"> ● Recording paper is not installed in the manual input tray. Install paper (page 32).
"PAPER JAMMED" "OPEN TOP COVER"	<ul style="list-style-type: none"> ● A recording paper jam occurred. Remove the jammed paper (page 82).
"PC FAIL OR BUSY"	<ul style="list-style-type: none"> ● The cable or the computer power cord is not connected correctly. Check the connections (page 21, 29). ● The software is not running on the computer. Restart the software and try again.
"PLEASE WAIT"	<ul style="list-style-type: none"> ● The unit is warming up. Wait for a while.
"POLLING ERROR"	<ul style="list-style-type: none"> ● The other party's fax machine does not offer the polling function. Check with the other party.
"REDIAL TIME OUT"	<ul style="list-style-type: none"> ● The other party's fax machine is busy or has run out of recording paper. Try again.
"REMOVE DOCUMENT"	<ul style="list-style-type: none"> ● The document is jammed. Remove the jammed document (page 87). ● Attempted to send or copy a document longer than 600 mm using the auto document feeder. Press [STOP] to remove the document. Divide the document into two or more sheets and try again.
"REMOVE PAPER IN INPUT TRAY #2"	<ul style="list-style-type: none"> ● The recording paper is installed in the manual input tray when trying to copy, receive faxes or print reports. Remove the recording paper from manual input tray.
"REPLACE DRUM CHANGE SUPPLIES"	<ul style="list-style-type: none"> ● The drum unit's service life is finished. Replace the drum unit immediately.
"RX MEMORY FULL"	<ul style="list-style-type: none"> ● The memory is full of received documents due to a lack of recording paper or a recording paper jam. Install paper (page 18) or remove the jammed paper (page 82). ● If feature #442 is set to "ALWAYS" (page 61), check the connection between the computer and the unit.
"TONER EMPTY" "CHANGE SUPPLIES"	<ul style="list-style-type: none"> ● The toner's service life is finished. Replace the toner cartridge immediately.
"TONER LOW" "CHANGE SUPPLIES"	<ul style="list-style-type: none"> ● The toner's service life is near to an end. Replace the toner cartridge as soon as possible.
"TOP COVER OPEN"	<ul style="list-style-type: none"> ● The top cover is open. Close it.
"TRANSMIT ERROR"	<ul style="list-style-type: none"> ● A transmission error occurred. Try again.
"WARMING UP"	<ul style="list-style-type: none"> ● The inside of the unit is cold. Let the unit warm up. Wait for a while.
"WRONG PAPER"	<ul style="list-style-type: none"> ● The fax message was printed on paper which is shorter than A4 size paper. Use the appropriate size paper (page 93).

11.3 When a function does not work

11.3.1 General

Problem	Cause & Solution
The unit does not work.	<ul style="list-style-type: none"> Check the connections (page 21, 32).
The output tray becomes full quickly or the recording paper does not stack properly on the output tray.	<ul style="list-style-type: none"> High humidity may cause the recording paper to curl. Try turning the paper over and re-inserting it. If the curl on the paper is heavy, please remove it from the output tray. If you still have this problem, contact our service personnel.
I cannot adjust volumes or display items stored in one-touch dial and navigator directory (KX-MB773/KX-MB783 only).	<ul style="list-style-type: none"> The unit is set to the scan mode or copy mode. Press [FAX] to switch modes. If you still have this problem, contact our service personnel.
A printing error is displayed while using PC FAX and Remote Control (KX-MB773/KX-MB783 only).	<ul style="list-style-type: none"> This is because the printer driver is used for PC FAX and Remote Control. The transmission error will be displayed as the printing error.
Multi-Function Station does not work properly.	<ul style="list-style-type: none"> If you connect the USB cable to USB hub, connect it to the USB port of your computer directly. Make sure you have installed the latest Service Pack available for the version of Windows installed on your computer. See the Microsoft web site for details. If you have any other multifunction softwares installed on your computer, uninstall them. Check that your computer has enough memory and hard disk space. If your computer warns of insufficient memory, close other applications. If there is not enough space on the hard disk, delete unnecessary files. Uninstall Multi-Function Station once, and re-install it.
I cannot install or uninstall Multi-Function Station.	<ul style="list-style-type: none"> Some of the files needed to install or uninstall Multi-Function Station may be corrupted. Use the MfsCleaner utility (found on the included CD-ROM) to solve the problem. <ol style="list-style-type: none"> Insert the included CD-ROM into your CD-ROM drive. <ul style="list-style-type: none"> The setup program will start automatically. [Tools] → [Cleanup Tool] <ul style="list-style-type: none"> The [MfsCleaner] window will appear. Click [Clean], then click [Yes] to restart the computer. <p>Note:</p> <ul style="list-style-type: none"> To install Multi-Function Station again, see page 28.
I cannot view the operating instructions using Multi-Function Station.	<ul style="list-style-type: none"> Install the operating instructions to your computer beforehand (page 29).

Problem	Cause & Solution
<p>I cannot find the unit in the [Target Device] or [Device Select] dialogue box when operating the following functions.</p> <ul style="list-style-type: none"> – Scanning – Remote Control – PC FAX (KX-MB773/KX-MB783 only) – Device Monitor 	<ul style="list-style-type: none"> ● The printer driver has not been installed. Install it on your computer (page 28).

11.3.2 Printing problems

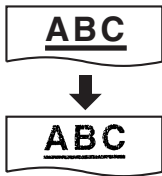
Problem	Cause & Solution
<p>The printing quality is poor.</p> 	<ul style="list-style-type: none"> ● Some paper has instructions recommending which side to print on. Try turning the recording paper over. ● You may have used paper with a cotton and/or fibre content that is over 20%, such as letterhead or resume paper. ● The recording paper is too damp. Use new paper. ● The remaining toner is low. Replace the toner cartridge. ● To check the drum life and quality, please print the printer test list (page 92). If printing quality is still poor, replace the toner cartridge and drum unit. ● The toner save mode of feature #482 is ON (page 58).
<p>A blank sheet is ejected.</p>	<ul style="list-style-type: none"> ● You placed the document facing the wrong way when using the copier. ● The other party placed the document in their fax machine the wrong way. Check with the other party (KX-MB773/KX-MB783 only).
<p>Black lines, white lines or smudges appear on the printed documents.</p>	<ul style="list-style-type: none"> ● The glass or rollers are dirty with correction fluid, etc. Clean them (page 88, 91). Please do not insert a document before correction fluid has dried completely.
<p>Coloured text is printed in black instead of greyscale when printing from Microsoft PowerPoint or other applications.</p>	<ul style="list-style-type: none"> ● Select [Colour] or remove the check next to [Greyscale] in the print dialogue so that coloured text will be printed in greyscale.

11.3.3 Scanner

Problem	Cause & Solution
<p>I cannot scan.</p>	<ul style="list-style-type: none"> ● When scanning at a high resolution, a large amount of available memory is required. If your computer warns of insufficient memory, close other applications and try again. ● The unit is in use. Try again later. ● There is not enough space on the hard disk. Delete unnecessary files and try again. ● Restart the computer, and try again. ● Check the connection between the computer and the unit (page 21, 29). ● You attempted to scan a document longer than the paper size which you set. Change the setting or divide the document into the appropriate paper size, and try again.
<p>The document is not fed into the unit when using the unit as a scanner (KX-MB773/KX-MB783 only).</p>	<ul style="list-style-type: none"> ● Remove the document in the auto document feeder and re-insert it.

11. Help

Problem	Cause & Solution
Even after clicking [Cancel], scanning continues.	<ul style="list-style-type: none">● Please wait. It may take a while for the cancel request to be accepted.
The name of the desired computer will not be displayed on the unit when scanning documents from the unit (KX-MB783, LAN connection only).	<ul style="list-style-type: none">● The printer driver has not been installed. Install it on your computer (page 28).● The PC name list up feature has been set to [Off]. Set to [On] in the [Settings] (page 30).● The maximum number of computers on the LAN is connected to the unit (up to 30 computers). Set the PC name list up feature to [Off] on the other computers (page 30).● The IP address of the unit may have changed. To detect the IP address, proceed as follows. [Start] → [All Programs] or [Programs] → [Panasonic] → the unit's name → [IP Address Checker].<ul style="list-style-type: none">● The IP address for the unit will be detected.

11.3.4 Copier

Problem	Cause & Solution
The unit will not make a copy.	<ul style="list-style-type: none">● You cannot make a copy during programming. Make the copy after programming.● The document was not fed into the unit properly. Re-insert the document.● Recording paper is not installed or the unit has run out of paper. Install paper (page 18).● Recording paper is installed in the manual input tray. Remove the recording paper from the manual input tray.
Letters on the copied documents are not clear.	<ul style="list-style-type: none">● The original document is too dark or too light. Change the contrast setting by pressing [CONTRAST] repeatedly, and try again.
The copied documents are too dark and cannot be read.	<ul style="list-style-type: none">● You used a coloured paper as a document. Change the contrast (page 36) and make a lighter copy of the document, using "TEXT" resolution (page 36).

11.3.5 Fax (KX-MB773/KX-MB783 only)

Problem	Cause & Solution
I cannot send documents.	<ul style="list-style-type: none">● The telephone line cord is connected to the [EXT] jack on the unit. Connect to the [LINE] jack (page 21).● The other party's fax machine is busy or has run out of recording paper. Try again.● The other party's machine is not a fax machine. Check with the other party.● The other party's fax machine failed to answer the fax automatically. Send the fax manually (page 43).
I cannot send a fax overseas.	<ul style="list-style-type: none">● Use the overseas transmission mode (feature #411 on page 59).● Add two pauses at the end of the telephone number or dial manually.
The other party complains that letters on their received document are distorted.	<ul style="list-style-type: none">● If your line has special telephone services such as call waiting, the service may have been activated during fax transmission. Connect the unit to a line that does not have these services.● Another telephone on the same line is off the hook. Hang up the extension telephone and try again.

Problem	Cause & Solution
The other party complains about the quality of their received documents.	<ul style="list-style-type: none"> ● Try copying the document. If the copied image is clear, there may be something wrong with the other party's machine. If the copied image is not clear, too dark, black and white lines or smudges appear, refer to "11.3.2 Printing problems", page 75. ● The original document is too dark or too light. Change the contrast setting by pressing [CONTRAST] repeatedly, and try again.
The other party complains that received documents are too dark and cannot be read.	<ul style="list-style-type: none"> ● You used a coloured paper as a document. Change the contrast (page 36) and make a lighter copy of the document, using "TEXT" resolution (page 36), and try again.
I cannot receive documents.	<ul style="list-style-type: none"> ● The telephone line cord is connected to the [EXT] jack on the unit. Connect to the [LINE] jack (page 21). ● Feature #442 is activated and the received fax documents are automatically transferred to the computer. View the received documents using the computer (page 52). ● Recording paper is installed in the manual input tray. Remove the recording paper from the manual input tray.
I cannot receive documents automatically.	<ul style="list-style-type: none"> ● The receiving mode is set to TEL mode. Set to FAX ONLY mode (page 48) or TEL/FAX mode (page 49). ● The time taken to answer the call is too long. Decrease the number of rings before the unit answers a call (feature #210 on page 57).
The display shows "CONNECTING", but faxes are not received.	<ul style="list-style-type: none"> ● The incoming call is not a fax. Change the receiving mode to TEL mode (page 49) or TEL/FAX mode (page 49).
The printing quality of the received documents is poor.	<ul style="list-style-type: none"> ● If documents can be copied properly, the unit is working normally. The other party may have sent a faint document or there may be something wrong with the other party's machine. Ask them to send a clearer copy of the document or to check their fax machine. ● If documents can not be copied properly, refer to "11.3.2 Printing problems", page 75.
The other party complains that they cannot send a document.	<ul style="list-style-type: none"> ● The memory is full of received documents due to a lack of recording paper or a recording paper jam. Install paper (page 18) or remove the jammed paper (page 82). ● If feature #442 is set to "ALWAYS" (page 61), check the connection between the computer and the unit. ● The unit is not in FAX ONLY mode. Press [FAX AUTO ANSWER] repeatedly to turn ON the [FAX AUTO ANSWER] light.
I cannot select the desired receiving mode.	<ul style="list-style-type: none"> ● If you want to set FAX ONLY mode: <ul style="list-style-type: none"> – press [FAX AUTO ANSWER] repeatedly to turn ON the [FAX AUTO ANSWER] light. ● If you want to set TEL mode or TEL/FAX mode: <ul style="list-style-type: none"> – select the desired mode using feature #404 (page 59), and press [FAX AUTO ANSWER] repeatedly to turn OFF the [FAX AUTO ANSWER] light.
When an extension telephone is connected, I cannot receive documents by pressing [*][#][9].	<ul style="list-style-type: none"> ● You must set remote fax activation to ON (feature #434 on page 61) beforehand. ● Press [*][#][9] firmly. ● You may have changed the remote fax activation code from [*][#][9] (default setting). Verify the remote fax activation code (feature #434 on page 61).

11. Help

Problem	Cause & Solution
I cannot hear a dial tone.	<ul style="list-style-type: none">● The telephone line cord is connected to the [EXT] jack on the unit. Connect to the [LINE] jack (page 21).● If you use a splitter/coupler to connect the unit, remove the splitter/coupler and connect the unit to the wall jack directly. If the unit operates properly, check the splitter/coupler.● Disconnect the unit from the telephone line and connect a known working telephone. If the working telephone operates properly, contact our service personnel to have the unit repaired. If the working telephone does not operate properly, contact your telephone company.● The power cord or telephone line cord is not connected. Check the connections (page 21).● If you connected the unit through a computer modem, connect the unit directly to a telephone line jack.
I cannot make calls.	<ul style="list-style-type: none">● The dialling mode setting may be wrong. Change the setting (feature #120 on page 22).
The unit does not ring.	<ul style="list-style-type: none">● The ringer volume is turned OFF. Adjust it (page 25).
The other party complains they only hear a fax tone and cannot talk.	<ul style="list-style-type: none">● FAX ONLY mode is set. Tell the other party the number is only used for faxes.
The [REDIAL] or [PAUSE] button does not function properly.	<ul style="list-style-type: none">● If this button is pressed during dialling, a pause will be inserted. If pressed immediately after a dial tone is obtained, the last number dialled will be redialled.
I cannot receive a fax document on the computer.	<ul style="list-style-type: none">● Make sure the following features are set beforehand.<ul style="list-style-type: none">– PC fax reception (feature #442 on page 61)– Computer setting for the PC fax reception (feature #443 on page 27)

11.3.6 Network (KX-MB783 only)

Problem	Cause & Solution												
<p>I cannot operate the following functions.</p> <ul style="list-style-type: none"> – PC printing – Scanning – Remote Control – PC FAX – Device Monitor 	<ul style="list-style-type: none"> ● Confirm the LED via the LAN port of the main board. If the LED is glowing or blinking red, the network access is working correctly. If the LED is not glowing or blinking, confirm the LAN cable (category 5 straight cable) is connected to the LAN port of the main board correctly. ● If the LED is blinking and you cannot perform the desired operation, the IP address of the unit may have changed. To detect the IP address, proceed as follows. [Start] → [All Programs] or [Programs] → [Panasonic] → the unit's name → [IP Address Checker]. <ul style="list-style-type: none"> ● The IP address for the unit will be detected. <p>Note:</p> <ul style="list-style-type: none"> ● If the IP address cannot be detected, enter it manually (feature #501 on page 65). The IP address of the computer and the unit must be in the same local IP address class as shown below. Set the IP address in the range of the number specified in the class corresponding to your local network scale. <table border="1" data-bbox="513 755 1273 1022"> <thead> <tr> <th>Class</th> <th>Subnet mask</th> <th>IP address</th> </tr> </thead> <tbody> <tr> <td>Class A</td> <td>255.0.0.0</td> <td>10.0.0.1 - 10.255.255.254</td> </tr> <tr> <td>Class B</td> <td>255.255.0.0</td> <td>172.xx.0.1 - 172.xx.255.254^{*1}</td> </tr> <tr> <td>Class C</td> <td>255.255.255.0</td> <td>192.168.xx.1 - 192.168.xx.254^{*2}</td> </tr> </tbody> </table> <p>*1 "xx" should be the same value for the unit and for the computer, as shown in the following example. Example: 172.16.0.1 - 172.16.255.254 (The available range of "xx" is 16 - 31)</p> <p>*2 "xx" should be the same value for the unit and for the computer, as shown in the following example. Example: 192.168.0.1 - 192.168.0.254 (The available range of "xx" is 0 - 255)</p> <ul style="list-style-type: none"> ● Your firewall software is blocking the connection. Disable the firewall software or change the firewall settings to make the Multi-Function Station work properly. 	Class	Subnet mask	IP address	Class A	255.0.0.0	10.0.0.1 - 10.255.255.254	Class B	255.255.0.0	172.xx.0.1 - 172.xx.255.254 ^{*1}	Class C	255.255.255.0	192.168.xx.1 - 192.168.xx.254 ^{*2}
Class	Subnet mask	IP address											
Class A	255.0.0.0	10.0.0.1 - 10.255.255.254											
Class B	255.255.0.0	172.xx.0.1 - 172.xx.255.254 ^{*1}											
Class C	255.255.255.0	192.168.xx.1 - 192.168.xx.254 ^{*2}											
<p>The unit does not appear in the [Select a Network Device] dialogue box when installing Multi-Function Station.</p>	<ul style="list-style-type: none"> ● Your firewall software is blocking the connection and the setup program may not list any units. Consult your network administrator and temporarily disable the firewall software. 												

11. Help

Problem	Cause & Solution
The [Windows Security Alert] dialogue box appears and asks if you want to block [PCCMFLPD] and I cannot operate the following functions after installing the Microsoft Windows XP Service Pack 2. <ul style="list-style-type: none">– PC printing– Scanning– Remote Control– PC FAX– Device Monitor	<ul style="list-style-type: none">● Click [Keep Blocking] and run the Windows Firewall Setting Tool to allow the data transmission for Multi-Function Station (page 80).

11.3.7 Using an answering machine (KX-MB773/KX-MB783 only)

Problem	Cause & Solution
I cannot receive documents automatically.	<ul style="list-style-type: none">● Your greeting message on the answering machine is too long. Shorten the message. Record a message up to 10 seconds long.● The answering machine rings too many times. Set to 1 or 2 rings.
I cannot receive voice messages.	<ul style="list-style-type: none">● Check if the answering machine is turned ON and connected to the unit properly (page 50).● Set the number of rings on the answering machine to 1 or 2.
I pressed the remote access code to access the answering machine remotely, but the line was disconnected.	<ul style="list-style-type: none">● The code may include “#” which is used for certain features provided by telephone companies. Change the code on the answering machine to another number which does not include “#”.
Callers complain that they cannot send a document.	<ul style="list-style-type: none">● There is no room left in memory of your answering machine to record voice messages. See the operating instructions of the answering machine and erase unnecessary messages.● You set the answering machine to only give a greeting message.

11.3.8 If a power failure occurs

- The unit will not function.
- If any documents are stored in the memory (i.e. during copy, PC printing, fax transmission or fax reception), they will be lost.

KX-MB773/KX-MB783 only:

- The unit is not designed for making emergency telephone calls when the power fails. Alternative arrangements should be made for access to emergency services.
- Fax transmission and reception will be interrupted.
- Documents during fax transmission or fax reception will be lost.
- When power is restored, a power down report will be printed out stating which fax items in the memory have been erased.

11.3.9 Firewall setting tool for Microsoft Windows XP Service Pack 2/Windows Vista users (KX-MB783, LAN connection only)

After installing Microsoft Windows XP Service Pack 2/Windows Vista, you will not be able to use the following functions because the Windows Firewall feature will be activated and block the connection.

- Device Monitor
- LPD Manager (Network communication tool)

The Windows Firewall Setting Tool enables you to change the Windows Firewall security settings and to use the above functions properly.

- 1 Insert the CD-ROM that is included with the unit into your CD-ROM drive.
 - [Panasonic Setup] dialogue box will appear.
 - 2 [Tools] → [Windows Firewall Setting]
 - The [Windows Firewall Setting Tool] window will appear.
 - 3 [Add to the exceptions list] → [OK] → [OK]
-

To confirm the security settings (For Windows XP users)

1. [Start] → [Control Panel] → [Security Center]
 - The [Windows Security Center] window will appear.
 2. [Windows Firewall]
 - The [Windows Firewall] dialogue box will appear.
 3. Click the [Exceptions] tab.
 4. Confirm that [Panasonic Trap Monitor Service] and [PCCMFLPD] are displayed and checked on the [Programs and Services] list.
-

To confirm the security settings (For Windows Vista users)

1. [Start] → [Control Panel] → [Security Center]
 - The [Windows Security Center] window will appear.
2. [Windows Firewall]
 - The [Windows Firewall] dialogue box will appear.
3. [Change Settings]
 - The [User Access Control] dialogue box will appear.
4. [Continue]
5. Click the [Exceptions] tab.
6. Confirm that [Panasonic Trap Monitor Service], [PCMFSLM] and [PCCMFLPD] are displayed and checked on the [Program or Port] list.

12.1 Recording paper jam

12.1.1 When the recording paper has jammed inside of the unit

The display will show the following.

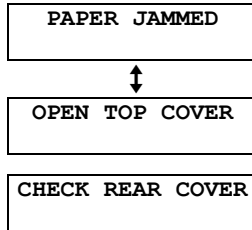

Caution:

- Do not pull out the jammed paper forcibly before opening the top cover.

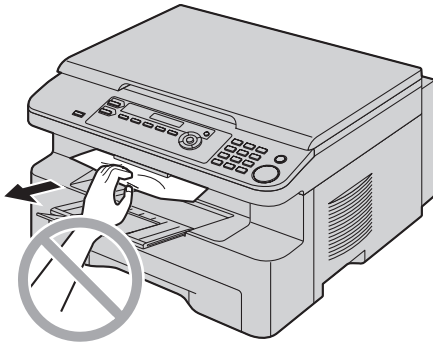

- To prevent injuries, be careful not to put your hands under the top cover.

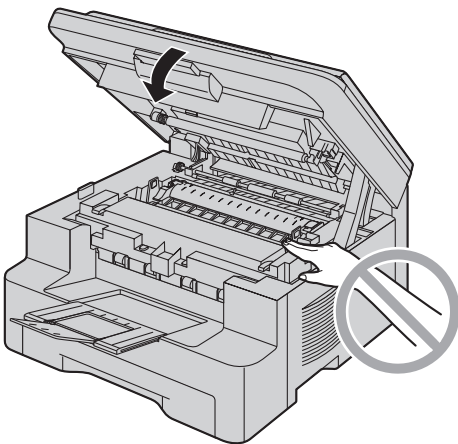

Case 1:

When the recording paper has jammed near the manual input tray:

1. Pull open the paper input tray (①).

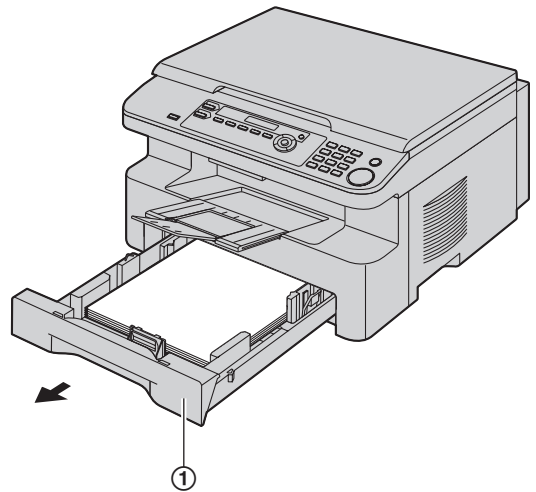

2. Open the manual input tray (②) and remove the jammed paper (③) carefully by pulling it upwards. Then close the manual input tray.

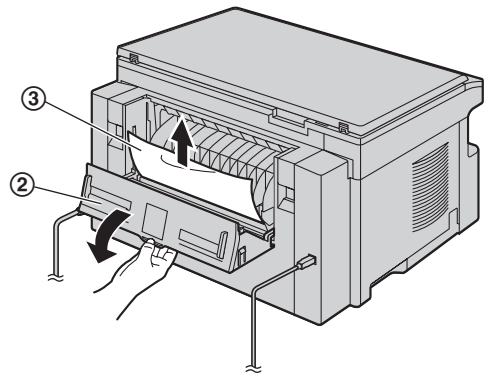

3. Close the paper input tray.

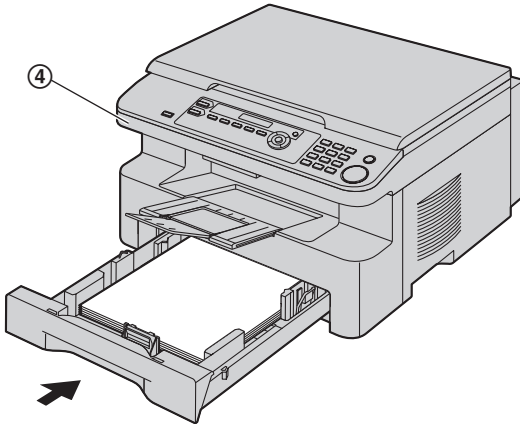

- Open and close the top cover (④) to clear the error message.

Case 2:

When the recording paper has jammed near the drum and toner unit:

1. Pull open the paper input tray (①).

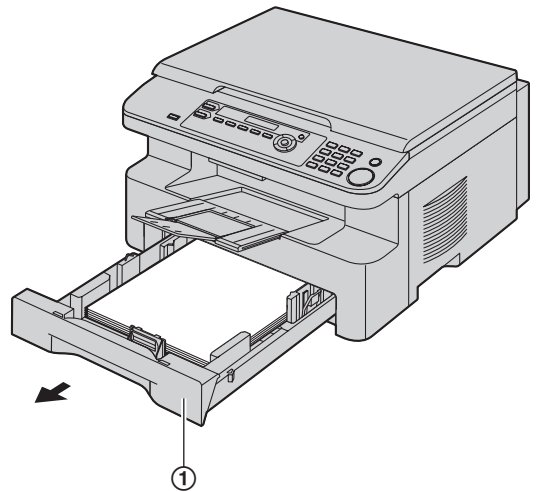

2. Lift the top cover release lever (②) and open the top cover (③).

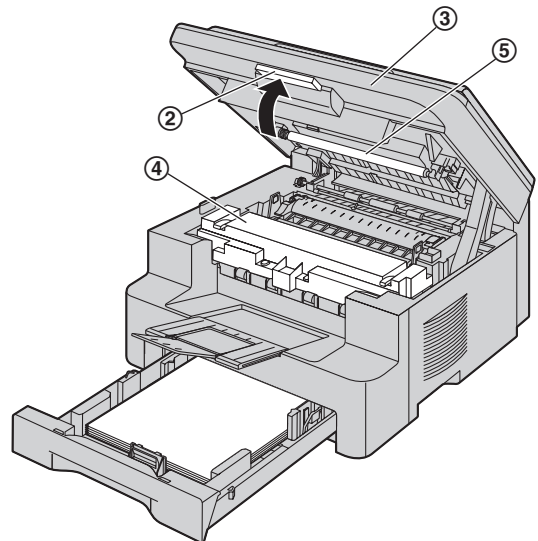

Caution:
The fuser unit (④) gets hot. Do not touch it.

Note:

- Do not touch the transfer roller (⑤).

12. Paper Jams

3. Remove the jammed paper (⑥) carefully by pulling it upwards.

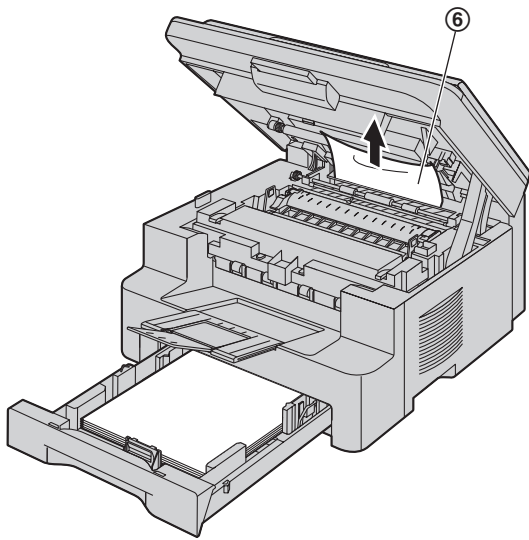

Remove the jammed paper (⑦) carefully by pulling it toward you.

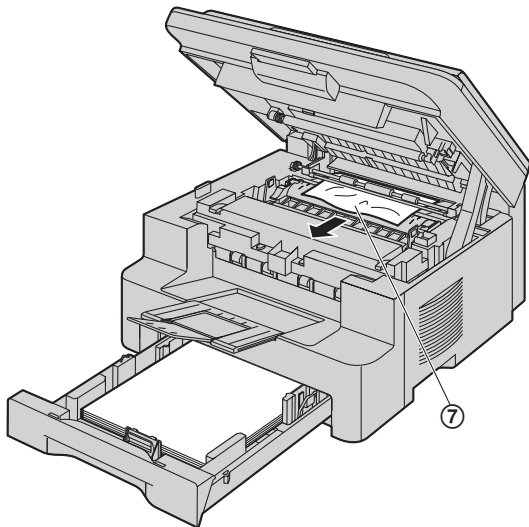

4. Close the paper input tray.

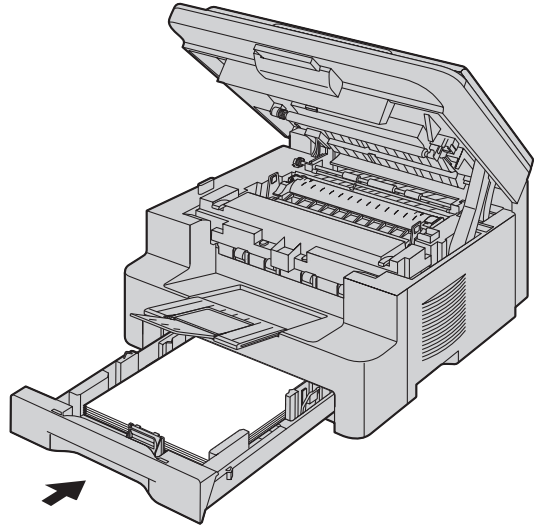

5. Close the top cover until locked.

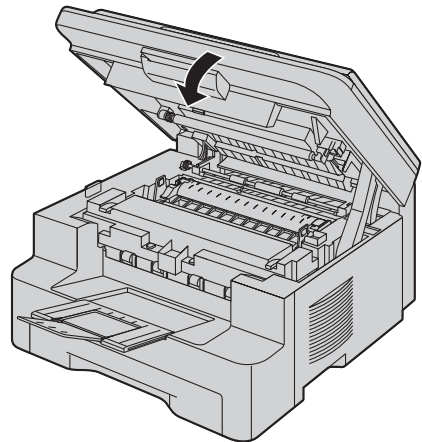

Case 3:
When the recording paper has jammed near the fuser unit:

1. Lift the top cover release lever (①) and open the top cover (②).

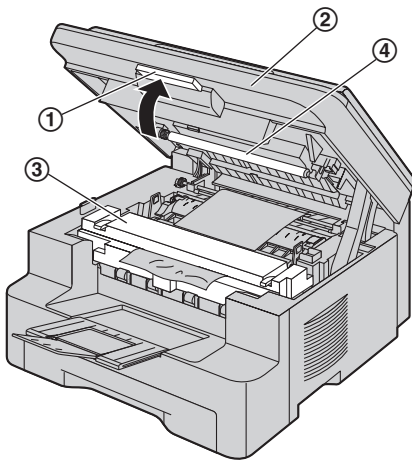

Caution:
 The fuser unit (③) gets hot. Do not touch it.

Note:

- Do not touch the transfer roller (④).

2. Lift both green levers (⑤) until they stop.

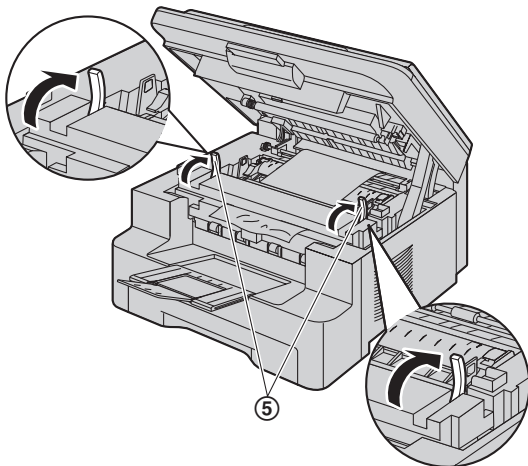

3. Remove the jammed paper (⑥) carefully by pulling it upwards.

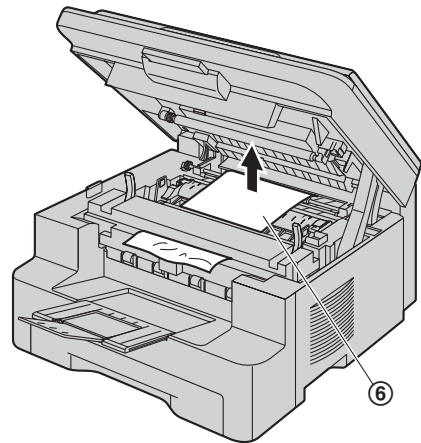

4. Push back the green levers (⑦) to the original position.

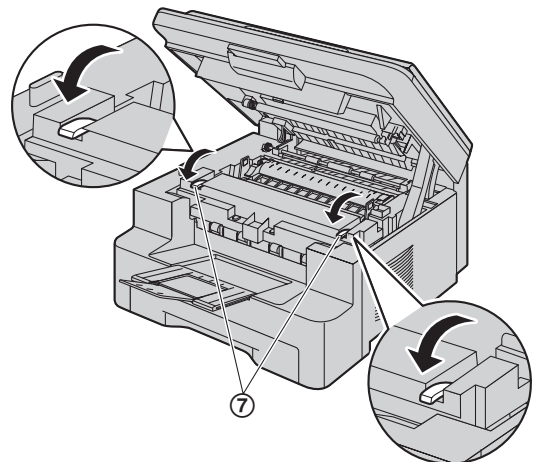

5. Close the top cover until locked.

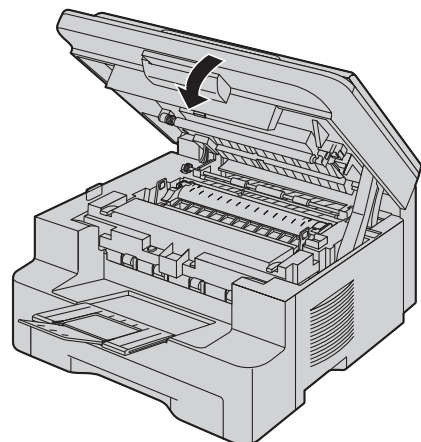

12. Paper Jams

12.1.2 When the recording paper is not fed into the unit properly

The display will show the following.

CHECK PAPER #1
PRESS START

- 1 Pull the paper input tray until it clicks into place, then pull it completely out, lifting the front part of the tray. Remove the recording paper and straighten.
- 2 Re-load the recording paper.

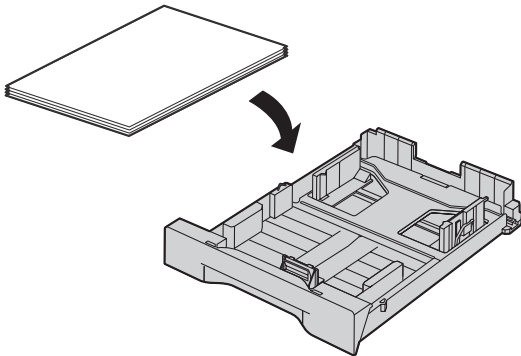

- 3 Insert the paper input tray to the unit, lifting the front part of the tray. Then push it completely into the unit.

Note:

- If the error message is still displayed, check the recording paper specifications and re-install recording paper. See page 18 for details.

12.1.3 When the recording paper in the manual input tray is not fed into the unit properly

The display will show the following.

CHECK PICK UP
INPUT TRAY #2

- 1 Remove the recording paper.
- 2 Re-insert the recording paper.

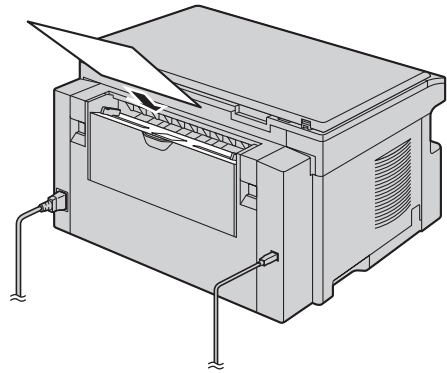

Note:

- If the error message is still displayed, check the recording paper specifications and re-install recording paper. See page 32 for details.

12.2 Document jams (Auto document feeder) (KX-MB773/KX-MB783 only)

Caution:

- Do not pull out the jammed document forcibly before lifting the ADF cover.

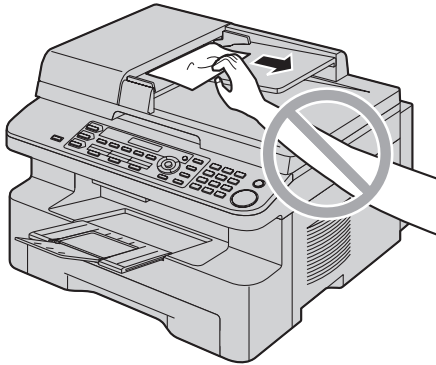

- Open the ADF cover (①) while holding the document cover (②).

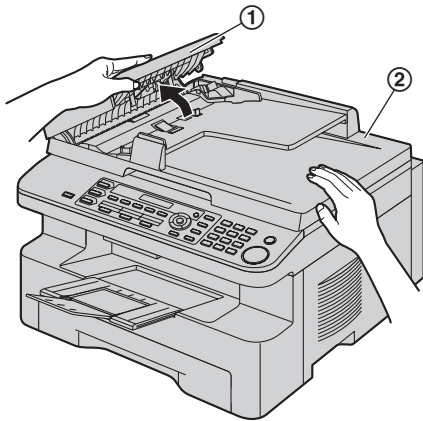

- Remove the jammed document (③) carefully.

When the document has jammed near the document entrance:

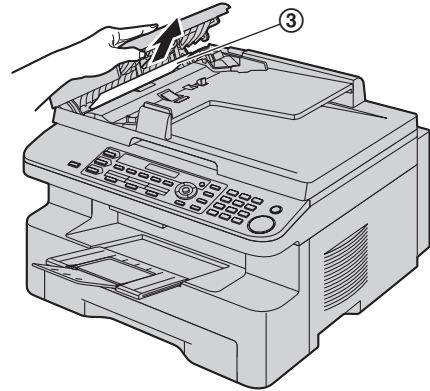

When the document has jammed near the document exit:

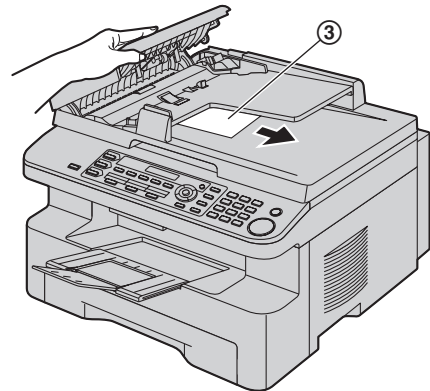

- Close the ADF cover.

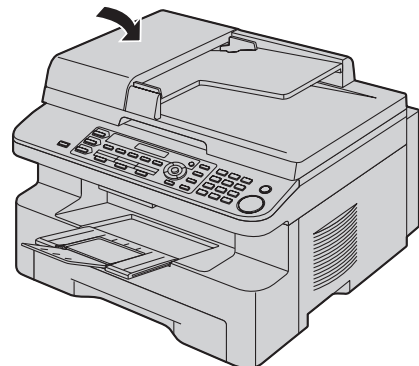

13. Cleaning

13.1 Cleaning the white plates and glass

Clean the white plates and glass when a black line, a white line or a dirty pattern appears on:

- your recording paper,
- the original document,
- the scanned data, or
- the fax document received by the other party (KX-MB773/KX-MB783 only).

Caution:

- Be careful when handling the drum and toner unit. See the caution for the drum unit on page 13 for details.
- Do not use paper products, such as paper towels or tissues, to clean the inside of the unit.

13.1.1 White plates and scanner glass

- 1 Open the document cover (①).

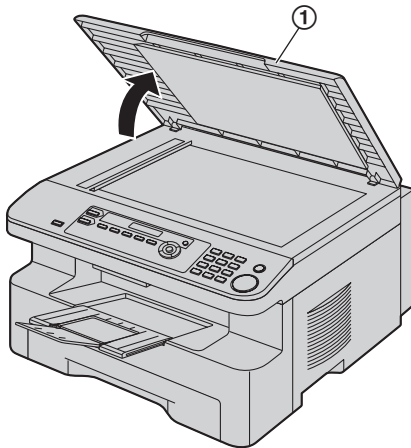

- 2 Hold the document cover (②) while cleaning the white plates (③) and the scanner glass (④).

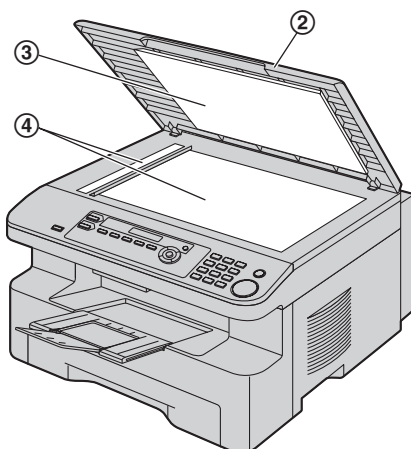

- 3 Close the document cover (⑤).

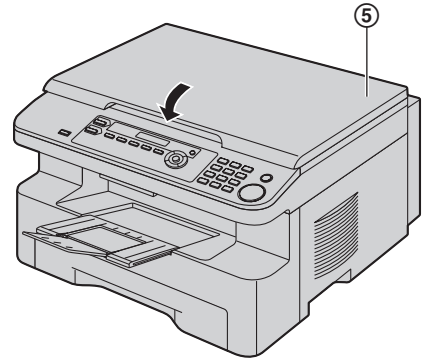

13.1.2 Lower glass

- 1 Disconnect the power cord.
- 2 Lift the top cover release lever (1) and open the top cover (2).

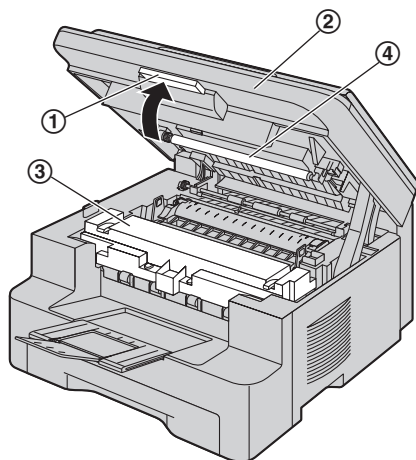

Caution:
The fuser unit (3) gets hot. Do not touch it.

Note:

- Do not touch the transfer roller (4).

- 3 Remove the drum and toner unit (5) by holding the tabs.

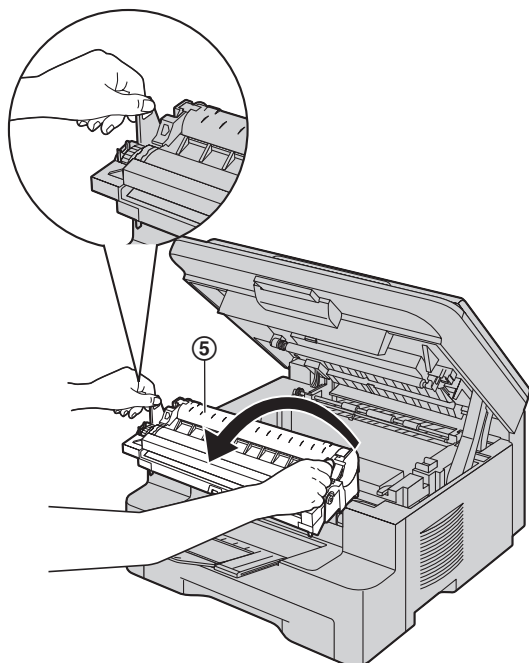

- 4 Clean the lower glass (6) with a soft and dry cloth.

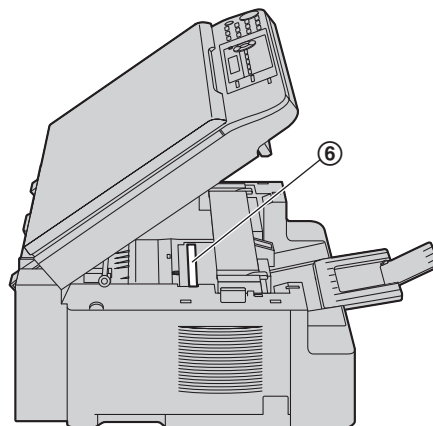

- 5 Reinstall the drum and toner unit (7) by holding the tabs.

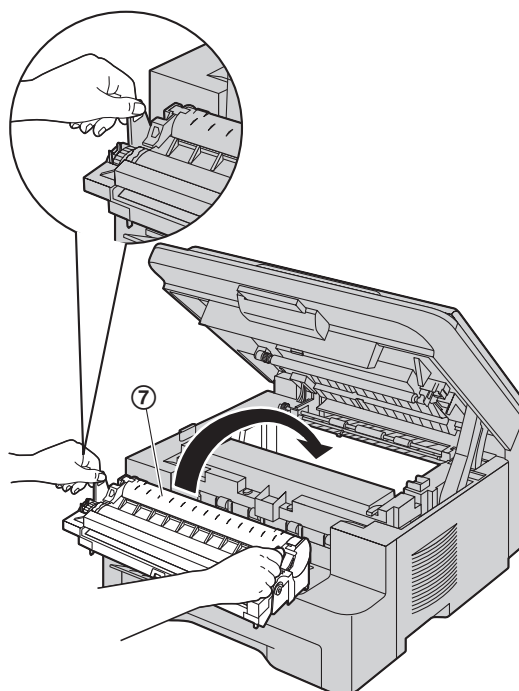

13. Cleaning

- Make sure that the triangles (⑧) match, to install the drum and toner unit correctly.

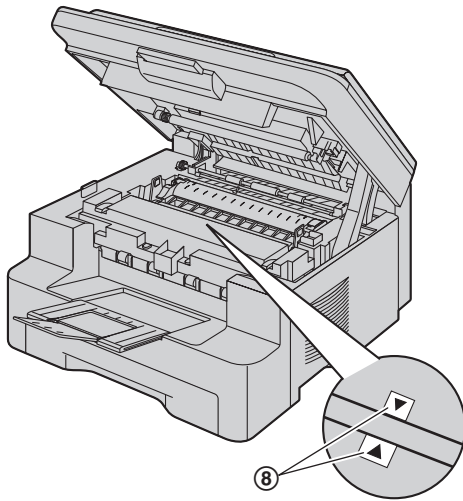

- 6 Close the top cover until locked.

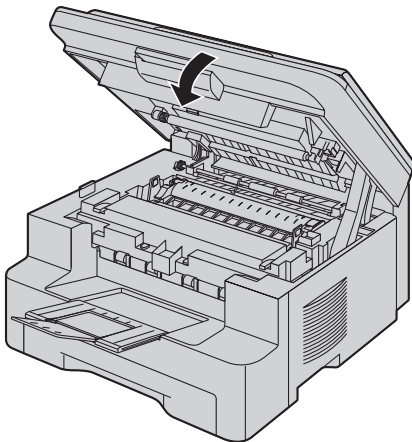

Caution:

- To prevent injuries, be careful not to put your hands under the top cover.

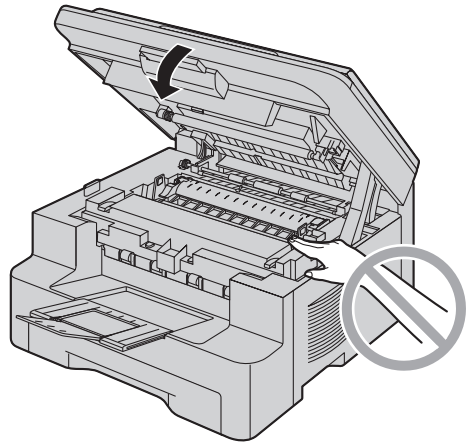

- 7 Re-connect the power cord.

13.2 Cleaning the document feeder rollers (KX-MB773/KX-MB783 only)

Clean the rollers when the document frequently misfeeds.

- 1 Disconnect the power cord.
- 2 Open the ADF cover (①) while holding the document cover (②).

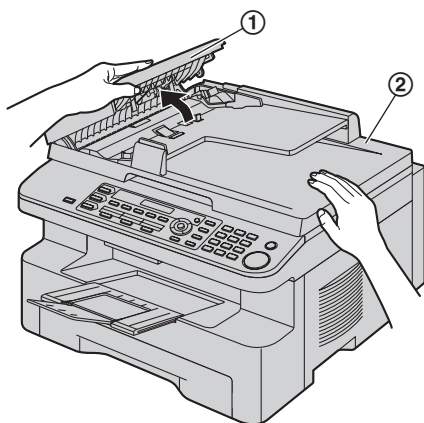

- 3 Clean the document feeder rollers (③) with a cloth moistened with isopropyl rubbing alcohol, and let all parts dry thoroughly.

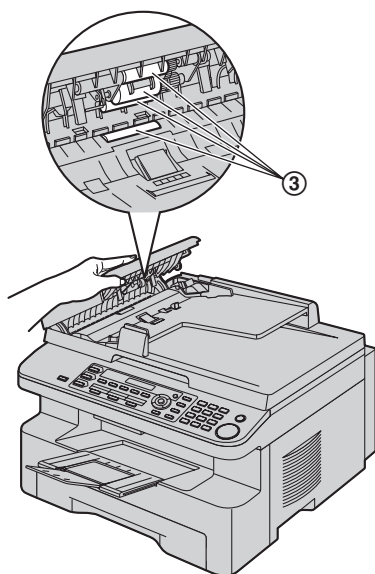

- 4 Close the ADF cover.

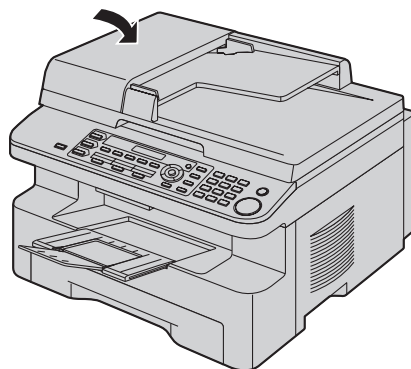

- 5 Re-connect the power cord.

14.1 Reference lists and reports

You can print out the following lists and reports for your reference.

- "SETUP LIST"
- "TEL NO. LIST"^{*1}
- "JOURNAL REPORT"^{*1}
- "BROADCAST LIST"^{*1}
- "PRINTER TEST"
 - If the test print has smudges, or blurred points or lines, clean the inside of the unit (page 88, 91). If printing quality is still poor, replace the toner cartridge and drum unit.
- "CALLER ID LIST"^{*1}
- "ADDRESS LIST"^{*2}

^{*1} KX-MB773/KX-MB783 only

^{*2} KX-MB783 only

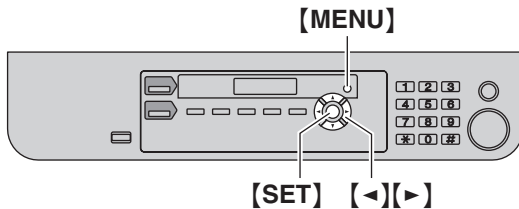

- 1 Press **[MENU]** repeatedly to display "PRINT REPORT".
- 2 Press **[←]** or **[→]** repeatedly to display the desired item.
- 3 Press **[SET]** to start printing. → **[MENU]**

14.2 Specifications

■ Applicable lines^{*1}:

Public Switched Telephone Network

■ Document size:

KX-MB263: Max. 216 mm in width, Max. 297 mm in length

KX-MB773/KX-MB783: Max. 216 mm in width, Max. 600 mm in length

■ Effective scanning width:

208 mm

■ Effective printing width:

A4: 202 mm

Letter/Legal: 208 mm

■ Transmission time^{*1*2}:

Approx. 4 s/page (ECM-MMR Memory transmission)^{*3}

■ Scanning density:

Scanning resolution:

Up to 600 × 1,200 dpi (Optical)

Up to 9,600 × 9,600 dpi (Interpolated)

Copy resolution:

Up to 600 × 600 dpi (Scanner glass)

Up to 600 × 300 dpi (Auto document feeder)^{*1}

Fax resolution^{*1}:

Horizontal: 8 pels/mm

Vertical: 3.85 lines/mm-in standard resolution,
7.7 lines/mm-in fine/photo resolution,

15.4 lines/mm-in super fine resolution

■ Photo resolution:

64-level

■ Scanner type:

Colour Contact Image Sensor

■ Printer type:

Laser Printer

■ Data compression system^{*1}:

Modified Huffman (MH), Modified READ (MR), Modified Modified READ (MMR)

■ Modem speed^{*1}:

33,600 / 31,200 / 28,800 / 26,400 / 24,000 / 21,600 /
19,200 / 16,800 / 14,400 / 12,000 / 9,600 / 7,200 / 4,800
/ 2,400 bps; Automatic Fallback

■ Operating environment:

10 °C – 32.5 °C, 20 % – 70 % RH (Relative Humidity)

■ Dimensions:

KX-MB263: Approx. height 255 mm × width 420 mm ×
depth 445 mm

KX-MB773/KX-MB783: Approx. height 305 mm × width
420 mm × depth 445 mm

■ Mass (Weight):

KX-MB263: Approx. 12 kg

KX-MB773/KX-MB783: Approx. 13 kg

■ Power consumption:

Standby: Approx. 6.5 W

Preheat: Approx. 65 W

Copy: Approx. 320 W

Maximum: Approx. 950 W (When the fuser lamp turns
on)

Power supply:

220–240 V AC, 50/60 Hz

Memory capacity**(for operation and storing memory):**

32 MB

Fax memory capacity*1:

2 MB in total

Approx. 170 pages of memory reception

Approx. 150 pages of memory transmission

(Based on the ITU-T No. 1 Test Chart in standard resolution, without using the Error Correction Mode.)

Laser diode properties:

Laser output: Max. 5 mW

Wave length: 760 nm – 810 nm

Emission duration: Continuous

Print speed:

Approx. 18 ppm (pages per minute)

Printing resolution:

600 × 600 dpi

*1 KX-MB773/KX-MB783 only

*2 Transmission speed depends on the contents of the pages, resolution, telephone line conditions and capability of the other party's machine.

*3 Transmission speed is based on the ITU-T No. 1 Test Chart with original mode. If the capability of the other party's machine is inferior to your unit, the transmission time may be longer.

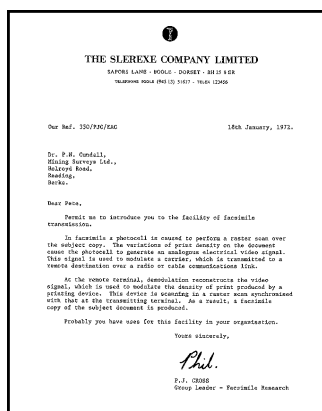
ITU-T No.1 Test Chart**Note:**

- Design and specifications are subject to change without notice.
- The pictures and illustrations in these instructions may vary slightly from the actual product.
- The accuracy of the clock is approximately ±60 seconds a month (KX-MB773/KX-MB783 only).

Recording paper specifications**Recording paper size:**

A4: 210 mm × 297 mm

Letter: 216 mm × 279 mm

Legal: 216 mm × 356 mm

Label size:

A4: 210 mm × 297 mm

Letter: 216 mm × 279 mm

Recording paper weight:60 g/m² to 90 g/m²**Note for recording paper:**

- We recommend that you test paper (especially special sizes and types of paper) on the unit before purchasing large quantities.
- Do not use the following types of paper:
 - Paper with cotton and/or fibre content that is over 20 %, such as letterhead paper or paper used for resumes
 - Extremely smooth or shiny paper, or paper that is highly textured
 - Coated, damaged or wrinkled paper
 - Paper with foreign objects attached, such as tabs or staples
 - Paper which has dust, lint or oil stains
 - Paper that will melt, vaporize, discolour, scorch or emit dangerous fumes near 200 °C, such as vellum paper. These materials may transfer onto the fusing roller and cause damage.
 - Moist paper
 - Inkjet paper
- Some paper only accepts print on one side. Try using the other side of the paper if you are not happy with the print quality or if misfeeding occurs.
- For proper paper feeding and best print quality, we recommend using long-grained paper.
- Do not use paper of different types or thickness at the same time. This may cause paper jams.
- Avoid double-sided printing.
- Do not use paper printed from this unit for double-sided printing with other copiers or printers. This may cause paper jams.
- To avoid curling, do not open paper packs until you are ready to use the paper. Store unused paper in the original packaging, in a cool and dry location.

14. General Information

Toner life

Toner life depends on the amount of content in a received, copied or printed document. The following is the approximate relationship between image area and toner life for replacement toner cartridge (Model No. KX-FAT92E/KX-FAT92X). Toner life varies in actual usage.

5 % image area

Approx. 2,000 sheets of A4 size paper can be printed.

Table of Contents

- 1 Table of Contents
- 1 Introduction and Installation Assessment
- 1.1 Included accessories
- 1.2 Accessory information
- 1.3 Finding the Contents
- 1.4 Description of features
- 1.5 Overview of features
- 1.6 Overview of installation
- 1.7 Overview of operation
- 1.8 Overview of paper
- 1.9 Overview of toner
- 1.10 Overview of maintenance
- 1.11 Overview of troubleshooting
- 1.12 Overview of safety
- 1.13 Overview of legal notices
- 1.14 Overview of warranty
- 1.15 Overview of contact information

Table of Contents

- 1 Table of Contents
- 1 Introduction and Installation Assessment
- 1.1 Included accessories
- 1.2 Accessory information
- 1.3 Finding the Contents
- 1.4 Description of features
- 1.5 Overview of features
- 1.6 Overview of installation
- 1.7 Overview of operation
- 1.8 Overview of paper
- 1.9 Overview of toner
- 1.10 Overview of maintenance
- 1.11 Overview of troubleshooting
- 1.12 Overview of safety
- 1.13 Overview of legal notices
- 1.14 Overview of warranty
- 1.15 Overview of contact information

Thank you for purchasing a Panasonic fax machine.
Please refer to the user manual for details.
Date of purchase
Serial number (found on the rear of the unit)
Dealer's name and address
Dealer's telephone number

10 % image area

Approx. 1,000 sheets of A4 size paper can be printed.

Table of Contents

- 1 Table of Contents
- 1 Introduction and Installation Assessment
- 1.1 Included accessories
- 1.2 Accessory information
- 1.3 Finding the Contents
- 1.4 Description of features
- 1.5 Overview of features
- 1.6 Overview of installation
- 1.7 Overview of operation
- 1.8 Overview of paper
- 1.9 Overview of toner
- 1.10 Overview of maintenance
- 1.11 Overview of troubleshooting
- 1.12 Overview of safety
- 1.13 Overview of legal notices
- 1.14 Overview of warranty
- 1.15 Overview of contact information

Table of Contents

- 1 Table of Contents
- 1 Introduction and Installation Assessment
- 1.1 Included accessories
- 1.2 Accessory information
- 1.3 Finding the Contents
- 1.4 Description of features
- 1.5 Overview of features
- 1.6 Overview of installation
- 1.7 Overview of operation
- 1.8 Overview of paper
- 1.9 Overview of toner
- 1.10 Overview of maintenance
- 1.11 Overview of troubleshooting
- 1.12 Overview of safety
- 1.13 Overview of legal notices
- 1.14 Overview of warranty
- 1.15 Overview of contact information

Thank you for purchasing a Panasonic fax machine.
Please refer to the user manual for details.
Date of purchase
Serial number (found on the rear of the unit)
Dealer's name and address
Dealer's telephone number

15 % image area

Approx. 650 sheets of A4 size paper can be printed.

Table of Contents

- 1 Table of Contents
- 1 Introduction and Installation Assessment
- 1.1 Included accessories
- 1.2 Accessory information
- 1.3 Finding the Contents
- 1.4 Description of features
- 1.5 Overview of features
- 1.6 Overview of installation
- 1.7 Overview of operation
- 1.8 Overview of paper
- 1.9 Overview of toner
- 1.10 Overview of maintenance
- 1.11 Overview of troubleshooting
- 1.12 Overview of safety
- 1.13 Overview of legal notices
- 1.14 Overview of warranty
- 1.15 Overview of contact information

Table of Contents

- 1 Table of Contents
- 1 Introduction and Installation Assessment
- 1.1 Included accessories
- 1.2 Accessory information
- 1.3 Finding the Contents
- 1.4 Description of features
- 1.5 Overview of features
- 1.6 Overview of installation
- 1.7 Overview of operation
- 1.8 Overview of paper
- 1.9 Overview of toner
- 1.10 Overview of maintenance
- 1.11 Overview of troubleshooting
- 1.12 Overview of safety
- 1.13 Overview of legal notices
- 1.14 Overview of warranty
- 1.15 Overview of contact information

Thank you for purchasing a Panasonic fax machine.
Please refer to the user manual for details.
Date of purchase
Serial number (found on the rear of the unit)
Dealer's name and address
Dealer's telephone number

Note:

- The image area changes with the depth, thickness and size of the characters.
- If you turn on the toner save feature, the toner cartridge will last approx. 40 % longer.

Drum life

The drum unit is a consumable item and needs to be replaced regularly. There are various factors that determine the actual drum life, such as temperature, humidity, type of paper and how much toner you use for the number of sheets per print job. The maximum drum life is approx. 6,000 sheets. The actual number of sheets your drum will print may be significantly less than this estimate if your unit is often used for printing small number sheets per job. Because many of the factors that determine the actual drum life cannot be controlled, we cannot guarantee a minimum number of sheets that will be printed by your drum.

14.3 Information of copyrights and licences (KX-MB783 only)

- This product uses a part of NetBSD kernel.

The use of a part of NetBSD kernel is based on the typical BSD style licence below.

Copyright (c)

The Regents of the University of California. All rights reserved.

Redistribution and use in source and binary forms, with or without modification, are permitted provided that the following conditions are met:

1. Redistributions of source code must retain the above copyright notice, this list of conditions and the following disclaimer.
2. Redistributions in binary form must reproduce the above copyright notice, this list of conditions and the following disclaimer in the documentation and/or other materials provided with the distribution.
3. All advertising materials mentioning features or use of this software must display the following acknowledgement:
This product includes software developed by the University of California, Berkeley and its contributors.
4. Neither the name of the University nor the names of its contributors may be used to endorse or promote products derived from this software without specific prior written permission.

THIS SOFTWARE IS PROVIDED BY THE REGENTS AND CONTRIBUTORS ``AS IS'' AND ANY EXPRESS OR IMPLIED WARRANTIES, INCLUDING, BUT NOT LIMITED TO, THE IMPLIED WARRANTIES OF MERCHANTABILITY AND FITNESS FOR A PARTICULAR PURPOSE ARE DISCLAIMED. IN NO EVENT SHALL THE REGENTS OR CONTRIBUTORS BE LIABLE FOR ANY DIRECT, INDIRECT, INCIDENTAL, SPECIAL, EXEMPLARY, OR CONSEQUENTIAL DAMAGES (INCLUDING, BUT NOT LIMITED TO, PROCUREMENT OF SUBSTITUTE GOODS OR SERVICES; LOSS OF USE, DATA, OR PROFITS; OR BUSINESS INTERRUPTION) HOWEVER CAUSED AND ON ANY THEORY OF LIABILITY, WHETHER IN CONTRACT, STRICT LIABILITY, OR TORT (INCLUDING NEGLIGENCE OR OTHERWISE) ARISING IN ANY WAY OUT OF THE USE OF THIS SOFTWARE, EVEN IF ADVISED OF THE POSSIBILITY OF SUCH DAMAGE.

However, parts of the NetBSD Kernel are provided with the following copyright notices.

Copyright (c) 1980, 1983, 1988, 1993 The Regents of the University of California. All rights reserved.

Copyright (c) 1980, 1986, 1989, 1993 The Regents of the University of California. All rights reserved.

Copyright (c) 1980, 1986, 1991, 1993 The Regents of the University of California. All rights reserved.

Copyright (c) 1980, 1986, 1993 The Regents of the University of California. All rights reserved.

Copyright (c) 1982, 1985, 1986, 1988, 1993, 1994 The Regents of the University of California. All rights reserved.

Copyright (c) 1982, 1986, 1988, 1990, 1993 The Regents of the University of California. All rights reserved.

Copyright (c) 1982, 1986, 1988, 1990, 1993, 1994, 1995 The Regents of the University of California. All rights reserved.

Copyright (c) 1982, 1986, 1988, 1990, 1993, 1995 The Regents of the University of California. All rights reserved.

Copyright (c) 1982, 1986, 1988, 1991, 1993 The Regents of the University of California. All rights reserved.

Copyright (c) 1982, 1986, 1988, 1993 The Regents of the University of California. All rights reserved.

Copyright (c) 1982, 1986, 1988, 1993, 1995 The Regents of the University of California. All rights reserved.

Copyright (c) 1982, 1986, 1989, 1991, 1993 The Regents of the University of California. All rights reserved.

Copyright (c) 1982, 1986, 1989, 1993 The Regents of the University of California. All rights reserved.

14. General Information

Copyright (c) 1982, 1986, 1990, 1991, 1993 The Regents of the University of California. All rights reserved.

Copyright (c) 1982, 1986, 1990, 1993 The Regents of the University of California. All rights reserved.

Copyright (c) 1982, 1986, 1990, 1993, 1994 The Regents of the University of California. All rights reserved.

Copyright (c) 1982, 1986, 1991, 1993 The Regents of the University of California. All rights reserved.

Copyright (c) 1982, 1986, 1991, 1993, 1994 The Regents of the University of California. All rights reserved.

Copyright (c) 1982, 1986, 1991, 1993, 1995 The Regents of the University of California. All rights reserved.

Copyright (c) 1982, 1986, 1993 The Regents of the University of California. All rights reserved.

Copyright (c) 1982, 1986, 1993, 1994 The Regents of the University of California. All rights reserved.

Copyright (c) 1982, 1986, 1993, 1994, 1995 The Regents of the University of California. All rights reserved.

Copyright (c) 1982, 1986, 1993, 1995 The Regents of the University of California. All rights reserved.

Copyright (c) 1982, 1988, 1991, 1993 The Regents of the University of California. All rights reserved.

Copyright (c) 1983, 1990, 1993 The Regents of the University of California. All rights reserved.

Copyright (c) 1983, 1993 The Regents of the University of California. All rights reserved.

Copyright (c) 1985, 1986, 1993 The Regents of the University of California. All rights reserved.

Copyright (c) 1985, 1986, 1993 The Regents of the University of California. All rights reserved.

Copyright (c) 1986, 1989, 1991, 1993 The Regents of the University of California. All rights reserved.

Copyright (c) 1986, 1993 The Regents of the University of California. All rights reserved.

Copyright (c) 1987, 1991, 1993 The Regents of the University of California. All rights reserved.

Copyright (c) 1987, 1993 The Regents of the University of California. All rights reserved.

Copyright (c) 1987, 1993 The Regents of the University of California. All rights reserved.

Copyright (c) 1988 Regents of the University of California. All rights reserved

Copyright (c) 1988 Stephen Deering.

Copyright (c) 1988 University of Utah.

Copyright (c) 1988, 1989, 1993 The Regents of the University of California. All rights reserved.

Copyright (c) 1988, 1991, 1993 The Regents of the University of California. All rights reserved.

Copyright (c) 1988, 1992, 1993 The Regents of the University of California. All rights reserved.

Copyright (c) 1988, 1993 The Regents of the University of California. All rights reserved.

Copyright (c) 1989 The Regents of the University of California. All rights reserved.

Copyright (c) 1989, 1991, 1993 The Regents of the University of California. All rights reserved.

Copyright (c) 1989, 1993 The Regents of the University of California. All rights reserved.

Copyright (c) 1989, 1993, 1994 The Regents of the University of California. All rights reserved.

Copyright (c) 1990, 1991, 1993 The Regents of the University of California. All rights reserved.

Copyright (c) 1990, 1993 The Regents of the University of California. All rights reserved.

Copyright (c) 1991, 1993 The Regents of the University of California. All rights reserved.

Copyright (c) 1991, 1993, 1994 The Regents of the University of California. All rights reserved.

Copyright (c) 1992 Regents of the University of California. All rights reserved.

Copyright (c) 1992, 1993 The Regents of the University of California. All rights reserved.

Copyright (c) 1993 The Regents of the University of California. All rights reserved.

Copyright (c) 1993 Adam Glass

Copyright (C) 1993 by Sun Microsystems, Inc. All rights reserved.

Copyright (c) 1994 Gordon W. Ross

Copyright (c) 1994 Winning Strategies, Inc. All rights reserved.

Copyright (c) 1995 The Regents of the University of California. All rights reserved.

Copyright (C) 1995, 1996, 1997, and 1998 WIDE Project. All rights reserved.

Copyright (c) 1996 The Regents of the University of California. All rights reserved.

Copyright (c) 1996 John S. Dyson All rights reserved.

Copyright (c) 1996 Matt Thomas. All rights reserved.

Copyright (c) 1996 Matthew R. Green. All rights reserved.

Copyright (c) 1996 Paul Kranenburg

Copyright (c) 1996, 1997, 1999, 2001 The NetBSD Foundation, Inc. All rights reserved.

Copyright (c) 1996, 2000 Christopher G. Demetriou. All rights reserved.

Copyright (c) 1996,1999 by Internet Software Consortium.
 Copyright (c) 1996-1999 by Internet Software Consortium.
 Copyright (c) 1997 Jonathan Stone and Jason R. Thorpe. All rights reserved.
 Copyright (c) 1997 Christos Zoulas. All rights reserved.
 Copyright (c) 1997 Manuel Bouyer. All rights reserved.
 Copyright (c) 1997, 1998 The NetBSD Foundation, Inc. All rights reserved.
 Copyright (c) 1997, 1998, 1999, 2000 The NetBSD Foundation, Inc. All rights reserved.
 Copyright (c) 1997, 1998, 1999, 2001 The NetBSD Foundation, Inc. All rights reserved.
 Copyright (c) 1997, 1998, 1999, 2002 The NetBSD Foundation, Inc. All rights reserved.
 Copyright (c) 1997, 1998, 2000, 2001 The NetBSD Foundation, Inc. All rights reserved.
 Copyright (c) 1997, 1998, 2001 The NetBSD Foundation, Inc. All rights reserved.
 Copyright (c) 1997,98 The NetBSD Foundation, Inc. All rights reserved.
 Copyright (C) 1997-2000 Sony Computer Science Laboratories Inc. All rights reserved.
 Copyright (c) 1997-2002 The NetBSD Foundation, Inc. All rights reserved.
 Copyright (c) 1998 The NetBSD Foundation, Inc. All rights reserved.
 Copyright (c) 1998 Todd C. Miller <Todd.Miller@courtesan.com> All rights reserved.
 Copyright (c) 1998, 1999 The NetBSD Foundation, Inc. All rights reserved.
 Copyright (c) 1998, 1999, 2000 The NetBSD Foundation, Inc. All rights reserved.
 Copyright (c) 1998, 1999, 2000, 2001 The NetBSD Foundation, Inc. All rights reserved.
 Copyright (c) 1998, 2000 The NetBSD Foundation, Inc. All rights reserved.
 Copyright (c) 1998, 2000, 2001 The NetBSD Foundation, Inc. All rights reserved.
 Copyright (c) 1999 The NetBSD Foundation, Inc. All rights reserved.
 Copyright (C) 1999 WIDE Project. All rights reserved.
 Copyright (c) 1999, 2000 Jason L. Wright (jason@thought.net) All rights reserved.
 Copyright (c) 1999, 2000 The NetBSD Foundation, Inc. All rights reserved.
 Copyright (c) 1999, 2000, 2001 The NetBSD Foundation, Inc. All rights reserved.
 Copyright (c) 1999, 2001 The NetBSD Foundation, Inc. All rights reserved.
 Copyright (c) 2000 The NetBSD Foundation, Inc. All rights reserved.
 Copyright (c) 2000, 2001 The NetBSD Foundation, Inc. All rights reserved.
 Copyright (c) 2000, 2001, 2002 The NetBSD Foundation, Inc. All rights reserved.
 Copyright (c) 2001 The NetBSD Foundation, Inc. All rights reserved.
 Copyright (c) 2002 The NetBSD Foundation, Inc. All rights reserved.
 Copyright 1998 Massachusetts Institute of Technology. All rights reserved.
 Copyright 2001 Wasabi Systems, Inc. All rights reserved.
 Portions Copyright (c) 1993 by Digital Equipment Corporation.
 Portions Copyright (c) 1995 by International Business Machines, Inc.
 Copyright (c) 1983, 1989 The Regents of the University of California. All rights reserved.
 Copyright (c) 1996 by Internet Software Consortium. All rights reserved.
 Copyright (c) 1980, 1986, 1989 Regents of the University of California. All rights reserved.
 Copyright (c) 1988 The Regents of the University of California. All rights reserved.
 Copyright (c) 1992, 1993 The Regents of the University of California. All rights reserved.
 Copyright (c) 1994 Christopher G. Demetriou. All rights reserved.
 Copyright (c) 1997 The NetBSD Foundation, Inc. All rights reserved.
 Copyright (c) 1999 The NetBSD Foundation, Inc. All rights reserved.
 Copyright (c) 2001 The NetBSD Foundation, Inc. All rights reserved.
 Copyright (c) 1996 Gardner Buchanan <gbuchanan@shl.com> All rights reserved.

Parts of the NetBSD Kernel are provided with the licences that are slightly different from the above Berkeley-formed licence. Please refer the source code of the NetBSD Kernel about the details.

The source code of the NetBSD Kernel is provided by the NetBSD CVS Repositories (<http://cvsweb.netbsd.org/bsdweb.cgi/>), and this product includes parts of the source code in the following directories.

<http://cvsweb.netbsd.org/bsdweb.cgi/src/sys/kern/>
<http://cvsweb.netbsd.org/bsdweb.cgi/src/sys/net/>
<http://cvsweb.netbsd.org/bsdweb.cgi/src/sys/netinet/>

14. General Information

- This product contains Net-SNMP software and is using it based on the following licence conditions.

---- Part 1: CMU/UCD copyright notice: (BSD like) ----

Copyright 1989, 1991, 1992 by Carnegie Mellon University

Derivative Work - 1996, 1998-2000

Copyright 1996, 1998-2000 The Regents of the University of California

All Rights Reserved

Permission to use, copy, modify and distribute this software and its documentation for any purpose and without fee is hereby granted, provided that the above copyright notice appears in all copies and that both that copyright notice and this permission notice appear in supporting documentation, and that the name of CMU and The Regents of the University of California not be used in advertising or publicity pertaining to distribution of the software without specific written permission.

CMU AND THE REGENTS OF THE UNIVERSITY OF CALIFORNIA DISCLAIM ALL WARRANTIES WITH REGARD TO THIS SOFTWARE, INCLUDING ALL IMPLIED WARRANTIES OF MERCHANTABILITY AND FITNESS. IN NO EVENT SHALL CMU OR THE REGENTS OF THE UNIVERSITY OF CALIFORNIA BE LIABLE FOR ANY SPECIAL, INDIRECT OR CONSEQUENTIAL DAMAGES OR ANY DAMAGES WHATSOEVER RESULTING FROM THE LOSS OF USE, DATA OR PROFITS, WHETHER IN AN ACTION OF CONTRACT, NEGLIGENCE OR OTHER TORTIOUS ACTION, ARISING OUT OF OR IN CONNECTION WITH THE USE OR PERFORMANCE OF THIS SOFTWARE.

---- Part 2: Networks Associates Technology, Inc copyright notice (BSD) ----

Copyright (c) 2001-2003, Networks Associates Technology, Inc
All rights reserved.

Redistribution and use in source and binary forms, with or without modification, are permitted provided that the following conditions are met:

- * Redistributions of source code must retain the above copyright notice, this list of conditions and the following disclaimer.
- * Redistributions in binary form must reproduce the above copyright notice, this list of conditions and the following disclaimer in the documentation and/or other materials provided with the distribution.
- * Neither the name of the Networks Associates Technology, Inc nor the names of its contributors may be used to endorse or promote products derived from this software without specific prior written permission.

THIS SOFTWARE IS PROVIDED BY THE COPYRIGHT HOLDERS AND CONTRIBUTORS "AS IS" AND ANY EXPRESS OR IMPLIED WARRANTIES, INCLUDING, BUT NOT LIMITED TO, THE IMPLIED WARRANTIES OF MERCHANTABILITY AND FITNESS FOR A PARTICULAR PURPOSE ARE DISCLAIMED. IN NO EVENT SHALL THE COPYRIGHT HOLDERS OR CONTRIBUTORS BE LIABLE FOR ANY DIRECT, INDIRECT, INCIDENTAL, SPECIAL, EXEMPLARY, OR CONSEQUENTIAL DAMAGES (INCLUDING, BUT NOT LIMITED TO, PROCUREMENT OF SUBSTITUTE GOODS OR SERVICES; LOSS OF USE, DATA, OR PROFITS; OR BUSINESS INTERRUPTION) HOWEVER CAUSED AND ON ANY THEORY OF LIABILITY, WHETHER IN CONTRACT, STRICT LIABILITY, OR TORT (INCLUDING NEGLIGENCE OR OTHERWISE) ARISING IN ANY WAY OUT OF THE USE OF THIS SOFTWARE, EVEN IF ADVISED OF THE POSSIBILITY OF SUCH DAMAGE.

---- Part 3: Cambridge Broadband Ltd. copyright notice (BSD) ----

Portions of this code are copyright (c) 2001-2003, Cambridge Broadband Ltd. All rights reserved.

Redistribution and use in source and binary forms, with or without modification, are permitted provided that the following conditions are met:

- * Redistributions of source code must retain the above copyright notice, this list of conditions and the following disclaimer.
- * Redistributions in binary form must reproduce the above copyright notice, this list of conditions and the following disclaimer in the documentation and/or other materials provided with the distribution.
- * The name of Cambridge Broadband Ltd. may not be used to endorse or promote products derived from this software without specific prior written permission.

THIS SOFTWARE IS PROVIDED BY THE COPYRIGHT HOLDER ``AS IS" AND ANY EXPRESS OR IMPLIED WARRANTIES, INCLUDING, BUT NOT LIMITED TO, THE IMPLIED WARRANTIES OF MERCHANTABILITY AND FITNESS FOR A PARTICULAR PURPOSE ARE DISCLAIMED. IN NO EVENT SHALL THE COPYRIGHT HOLDER BE LIABLE FOR ANY DIRECT, INDIRECT, INCIDENTAL, SPECIAL, EXEMPLARY, OR CONSEQUENTIAL DAMAGES (INCLUDING, BUT NOT LIMITED TO, PROCUREMENT OF SUBSTITUTE GOODS OR SERVICES; LOSS OF USE, DATA, OR PROFITS; OR BUSINESS INTERRUPTION) HOWEVER CAUSED AND ON ANY THEORY OF LIABILITY, WHETHER IN CONTRACT, STRICT LIABILITY, OR TORT (INCLUDING NEGLIGENCE OR OTHERWISE) ARISING IN ANY WAY OUT OF THE USE OF THIS SOFTWARE, EVEN IF ADVISED OF THE POSSIBILITY OF SUCH DAMAGE.

---- Part 4: Sun Microsystems, Inc. copyright notice (BSD) ----

Copyright c 2003 Sun Microsystems, Inc., 4150 Network Circle, Santa Clara, California 95054, U.S.A. All rights reserved.

Use is subject to license terms below.

This distribution may include materials developed by third parties.

Sun, Sun Microsystems, the Sun logo and Solaris are trademarks or registered trademarks of Sun Microsystems, Inc. in the U.S. and other countries.

Redistribution and use in source and binary forms, with or without modification, are permitted provided that the following conditions are met:

- * Redistributions of source code must retain the above copyright notice, this list of conditions and the following disclaimer.
- * Redistributions in binary form must reproduce the above copyright notice, this list of conditions and the following disclaimer in the documentation and/or other materials provided with the distribution.
- * Neither the name of the Sun Microsystems, Inc. nor the names of its contributors may be used to endorse or promote products derived from this software without specific prior written permission.

THIS SOFTWARE IS PROVIDED BY THE COPYRIGHT HOLDERS AND CONTRIBUTORS ``AS IS" AND ANY EXPRESS OR IMPLIED WARRANTIES, INCLUDING, BUT NOT LIMITED TO, THE IMPLIED WARRANTIES OF MERCHANTABILITY AND FITNESS FOR A PARTICULAR PURPOSE ARE DISCLAIMED. IN NO EVENT SHALL THE COPYRIGHT HOLDERS OR CONTRIBUTORS BE LIABLE FOR ANY DIRECT, INDIRECT, INCIDENTAL, SPECIAL, EXEMPLARY, OR CONSEQUENTIAL

14. General Information

DAMAGES (INCLUDING, BUT NOT LIMITED TO, PROCUREMENT OF SUBSTITUTE GOODS OR SERVICES; LOSS OF USE, DATA, OR PROFITS; OR BUSINESS INTERRUPTION) HOWEVER CAUSED AND ON ANY THEORY OF LIABILITY, WHETHER IN CONTRACT, STRICT LIABILITY, OR TORT (INCLUDING NEGLIGENCE OR OTHERWISE) ARISING IN ANY WAY OUT OF THE USE OF THIS SOFTWARE, EVEN IF ADVISED OF THE POSSIBILITY OF SUCH DAMAGE.

Also this product contains software which includes following notices and licences.

Copyright 1988, 1989 by Carnegie Mellon University
Copyright 1989 TGV, Incorporated

All Rights Reserved

Permission to use, copy, modify, and distribute this software and its documentation for any purpose and without fee is hereby granted, provided that the above copyright notice appear in all copies and that both that copyright notice and this permission notice appear in supporting documentation, and that the name of CMU and TGV not be used in advertising or publicity pertaining to distribution of the software without specific, written prior permission.

CMU AND TGV DISCLAIMS ALL WARRANTIES WITH REGARD TO THIS SOFTWARE, INCLUDING ALL IMPLIED WARRANTIES OF MERCHANTABILITY AND FITNESS, IN NO EVENT SHALL CMU OR TGV BE LIABLE FOR ANY SPECIAL, INDIRECT OR CONSEQUENTIAL DAMAGES OR ANY DAMAGES WHATSOEVER RESULTING FROM LOSS OF USE, DATA OR PROFITS, WHETHER IN AN ACTION OF CONTRACT, NEGLIGENCE OR OTHER TORTIOUS ACTION, ARISING OUT OF OR IN CONNECTION WITH THE USE OR PERFORMANCE OF THIS SOFTWARE.

- This product contains thttpd software that ACMELabs developed and is using it based on the following licence conditions.

Copyright 1995,1998,1999,2000 by Jef Poskanzer <jef@acme.com>.

All rights reserved.

Redistribution and use in source and binary forms, with or without modification, are permitted provided that the following conditions are met:

1. Redistributions of source code must retain the above copyright notice, this list of conditions and the following disclaimer.
 2. Redistributions in binary form must reproduce the above copyright notice, this list of conditions and the following disclaimer in the documentation and/or other materials provided with the distribution.
- THIS SOFTWARE IS PROVIDED BY THE AUTHOR AND CONTRIBUTORS ``AS IS'' AND ANY EXPRESS OR IMPLIED WARRANTIES, INCLUDING, BUT NOT LIMITED TO, THE IMPLIED WARRANTIES OF MERCHANTABILITY AND FITNESS FOR A PARTICULAR PURPOSE ARE DISCLAIMED. IN NO EVENT SHALL THE AUTHOR OR CONTRIBUTORS BE LIABLE FOR ANY DIRECT, INDIRECT, INCIDENTAL, SPECIAL, EXEMPLARY, OR CONSEQUENTIAL DAMAGES (INCLUDING, BUT NOT LIMITED TO, PROCUREMENT OF SUBSTITUTE GOODS OR SERVICES; LOSS OF USE, DATA, OR PROFITS; OR BUSINESS INTERRUPTION) HOWEVER CAUSED AND ON ANY THEORY OF LIABILITY, WHETHER IN CONTRACT, STRICT LIABILITY, OR TORT (INCLUDING NEGLIGENCE OR OTHERWISE) ARISING IN ANY WAY OUT OF THE USE OF THIS SOFTWARE, EVEN IF ADVISED OF THE POSSIBILITY OF SUCH DAMAGE.

However, parts of the tthttpd software are provided with the following copyright notices.

Copyright 1995 by Jef Poskanzer <jef@acme.com>.

Copyright 1998 by Jef Poskanzer <jef@acme.com>.

Copyright 1999 by Jef Poskanzer <jef@acme.com>.

Copyright 1995,2000 by Jef Poskanzer <jef@acme.com>.

Copyright 1999,2000 by Jef Poskanzer <jef@acme.com>.

Copyright 1995,1998,2000 by Jef Poskanzer <jef@acme.com>.

- JPEG

This software is based in part on the work of the Independent JPEG Group.

15.1 Index

- # #101 Date and time: 25
- #102 Your logo: 26
- #103 Your fax number: 26
- #110 Language: 56
- #114 Location: 56
- #120 Dialling mode: 22
- #121 Recall/flash time: 56
- #145 LCD display contrast: 56
- #155 Change password: 57
- #161 Ringer pattern: 57
- #210 FAX ring count: 57
- #212 TEL/FAX ring count: 59
- #216 Automatic Caller ID list: 53
- #380 Paper size in the paper input tray: 57
- #401 Sending report: 43, 59
- #402 Automatic journal report: 44, 59
- #403 Power save: 57
- #404 Manual answer mode: 59
- #411 Overseas mode: 59
- #412 Delayed send: 60
- #413 ECM selection: 60
- #416 Connecting tone: 60
- #432 Auto reduction: 60
- #434 Fax activation code: 61
- #436 Silent fax ring count: 61
- #437 Memory reception alert: 61
- #438 Friendly reception: 61
- #442 PC fax setting: 61
- #443 PC fax reception: 27
- #459 Set fax features to default: 62
- #461 Default copy resolution: 63
- #462 Contrast hold: 57
- #463 Default operation mode: 58
- #464 Mode timer: 58
- #467 Page layout hold: 63
- #468 Zoom hold: 63
- #469 Collate hold: 63
- #482 Toner save: 16, 58
- #493 Scan mode: 64
- #494 Scan parameter hold: 64
- #500 DHCP mode: 65
- #501 IP address: 65
- #502 Subnet mask: 65
- #503 Default gateway: 65
- #504 DNS server #1: 65
- #505 DNS server #2: 65
- #507 Machine name: 65
- #508 MAC address: 65
- #532 Approved users: 65
- #533 Auto IP: 65
- #534 HTTPD: 66
- #774 Data timeout: 63
- A** Accessories: 10
- Address list: 92
- Answering machine: 50
- Approved users (Feature #532): 65
- Auto document feeder: 23, 37, 44
- Auto IP (Feature #533): 65
- Auto reduction (Feature #432): 60
- B** Basic features: 56
- Broadcast programming list: 92
- Broadcast transmission: 45
- C** Caller ID
- Calling back: 53
- Storing: 54
- Caller ID list (Feature #216): 53
- Character entry: 68
- Cleaning: 88, 91
- Collate hold (Feature #469): 63
- Connecting tone (Feature #416): 60
- Connections: 21
- LAN: 21
- USB: 28
- Contrast hold (Feature #462): 57
- Copy: 36
- Collation: 40
- Enlarge: 37
- N in 1: 39
- Poster: 39
- Proof set: 40
- Quick ID: 38
- Reduce: 37
- Reserve: 40
- Copy features: 63
- D** Data timeout (Feature #774): 63
- Date and time (Feature #101): 25
- Default copy resolution (Feature #461): 63
- Default gateway (Feature #503): 65
- Default operation mode (Feature #463): 58
- Delayed transmission (Feature #412): 60
- DHCP mode (Feature #500): 65
- Dialling mode (Feature #120): 22, 56
- Directory: 41
- Display
- Contrast (Feature #145): 56
- Error messages: 72
- DNS server #1 (Feature #504): 65
- DNS server #2 (Feature #505): 65
- Document size: 23
- Drum life: 94
- Drum unit: 13
- E** ECM selection (Feature #413): 60
- Error messages: 71, 72
- Extension telephone: 49
- F** Fax activation code (Feature #434): 61
- Fax features: 59
- Fax number (Feature #103): 26
- FAX ONLY mode: 48
- Flash time (Feature #121): 56
- Friendly reception (Feature #438): 61
- H** Help: 24
- Basic settings: 24
- Caller ID: 24

- Copier: 24
- Directory: 24
- Fax receiving: 24
- Feature list: 24
- Reports: 24
- HTTPD (Feature #534): 66
- I** IP address (Feature #501): 65
- J** Jams
 - Document: 87
 - Recording paper: 82
- Journal report (Feature #402): 44, 92
- Junk fax prohibitor: 51
- L** Label: 32
- LAN features: 65
- Language (Feature #110): 56
- Location (Feature #114): 56
- Logo (Feature #102): 26
- M** MAC address (Feature #508): 65
- Machine name (Feature #507): 65
- Manual answer mode (Feature #404): 59
- Manual input tray: 32
- Memory reception alert (Feature #437): 61
- Mode timer (Feature #464): 58
- Multi-Function Station software
 - Activating: 30
 - Installing: 28
 - Uninstalling: 29
- N** Navigator directory
 - Sending faxes: 45
 - Storing: 41
- Network features: 67
- O** OCR software: 34
- One-touch dial
 - Sending faxes: 45
 - Storing: 41
- Overseas mode (Feature #411): 59
- P** Page layout hold (Feature #467): 63
- Paper size
 - Paper input tray (Feature #380): 37
- Password (Feature #155): 57
- PC fax reception (Feature #443): 27
- PC fax setting (Feature #442): 61
- PC print features: 63
- Polling: 51
- Power failure: 80
- Power save (Feature #403): 57
- Printer test list: 92
- Programming: 55
- Pull scan: 35
- Push scan: 33
- Q** Quick scan: 44
- R** Recall time (Feature #121): 56
- Receiving faxes
 - Automatically: 48
 - Manually: 49
- Recording paper: 18
- Recording paper size: 93
- Redialling: 43, 45
- Reports
 - Address: 92
 - Broadcast programming: 92
 - Broadcast sending: 92
 - Caller ID: 57, 92
 - Journal: 44, 92
 - Power down: 80
 - Printer test: 92
 - Sending: 43, 59
 - Setup: 92
 - Telephone number: 92
- Reset fax features (Feature #459): 62
- Resolution: 36, 43
- Ring count
 - FAX ONLY (Feature #210): 57
 - Silent fax (Feature #436): 61
 - TEL/FAX (Feature #212): 59
- Ringer pattern (Feature #161): 25, 57
- S** Scan features: 64
- Scan mode (Feature #493): 64
- Scanner glass: 23, 36, 43
- Scan parameter hold (Feature #494): 64
- Sending faxes
 - Broadcast: 46
 - From memory: 44
 - Manually: 43
 - Navigator directory: 45
 - One-touch dial: 45
- Sending report (Feature #401): 43, 59
- Set fax default (Feature #459): 62
- Setup list: 92
- Storing
 - Broadcast: 45
 - Navigator directory: 41
 - One-touch dial: 41
- Subnet mask (Feature #502): 65
- T** Telephone number list: 92
- TEL mode: 49
- Toner cartridge: 13
- Toner life: 94
- Toner save (Feature #482): 16, 58
- V** Volume: 25
- Z** Zoom hold (Feature #468): 63

CE : KX-MB263
CE 0682 : KX-MB773/KX-MB783
with Fax function

Manufacturer:

Panasonic Communications Co., Ltd.

1-62, 4-chome, Minoshima, Hakata-ku, Fukuoka 812-8531, Japan

Global web site:

<http://panasonic.net>



MB263HX